

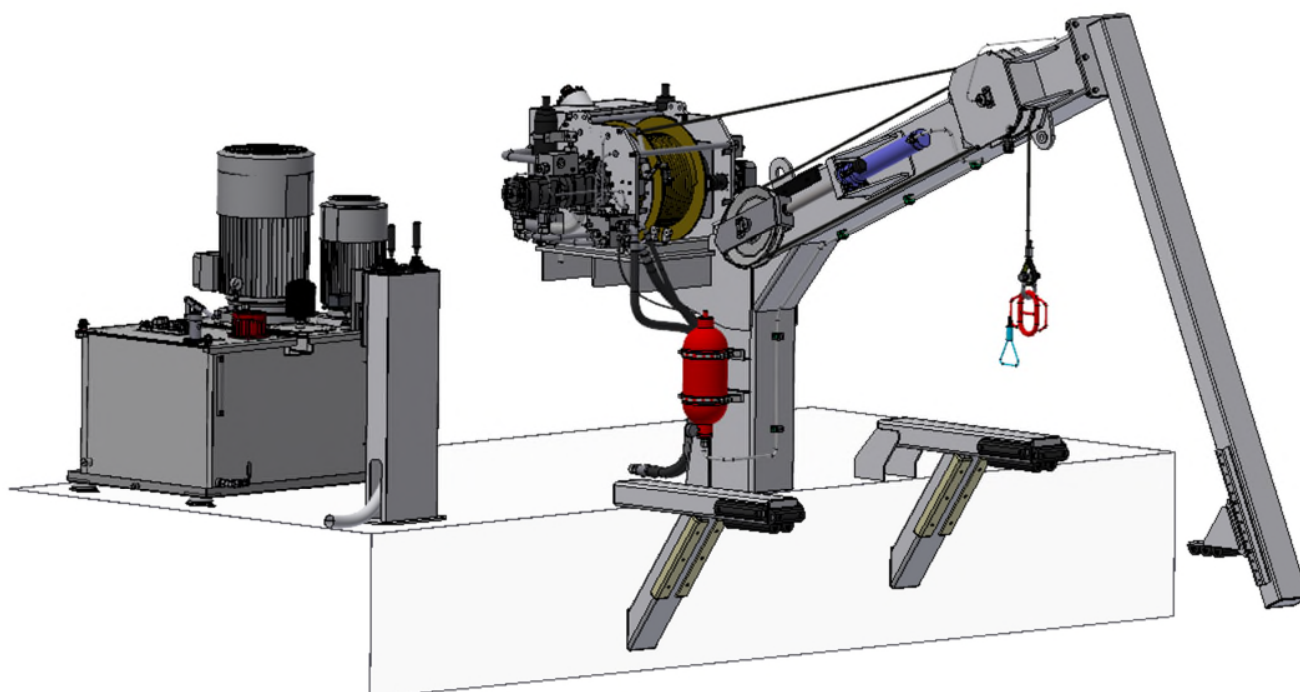

**VIKING
NORSAFE**
Boats and davits

Enterprise No.: NO940411696
www.VIKING-life.com

NDC-40 NO – Rescue boat Davit



TECHNICAL SPECIFICATION

VIKING Norsafe Life-Saving Equipment Norway AS

Tybakken 90, N-4818 Faervik
P.O. Box 115, N-4852 Faervik
Arendal, Norway

VIKING Project No.: TBA

VIKING Doc. No.: TSD-0024

Rev. Date: 18.06.2013

Rev. No: 1

Tel: +47 37 05 85 00

Fax: +47 37 05 85 01

E-mail: VIKING-Norsafe@VIKING-life.com

1. REGULATION AND CERTIFICATION

Applicable rules and regulations	In accordance with IMO/ SOLAS requirements, LSA Code and European Council Directive 2014/90/EU on Marine Equipment, Norsok R-002, DNVGL-ST-0378
Certificate	MED, DoC to Norsok R-002
Other certificate	Class certificate or flag acceptance on request

2. DAVIT SPECIFICATION

2.1. GENERAL DAVIT

Type	Rescue boat Davit
Model	NDC-40 NO
Application	Rescue boat handling
Drawing reference	G-501332, G-501328
Execution	Fixed cantilever davit
Boarding position	Inboard on deck level
Operating position	From deck side and from inside the boat (Gravity lowering)
Davit system weight	4630 kg, davit incl. winch (dry weight)
Safe Working Load (SWL)	4077 kg
Trim / list conditions	10° / 20° and 17° / 17°
Max. lowering height	60 m (including trim/list condition)
Operation temperature	-20°C till +40°C (other range on request)
Max. hoisting speed	50 m/min
Max. lowering speed	According to SOLAS regulation ($S = 0.4 + 0.02H$)
Manual hoisting	By manual hand-cranking
Wire sheaves	Galvanized, equipped with ball bearings
Installation	1 (one) deck welding point
Deck reinforcement requirements	See general arrangement drawing
Davit system H / W / D	See general arrangement drawing
Deck space required	See general arrangement drawing



Viking Norsafe R-002 rescue boat davit system is specifically designed for safe and efficient launch and recovery of Viking Norsafe rescue boats. It is intended for long term, reliable operation in harsh and hazardous marine and offshore environments. The davit and winch is designed in accordance with latest NORSOK R-002, LSA Code and DNV class notation DNVGL-ST-0378 requirements.

The davit comprises a fixed and cantilevered arm, wire dampening system and a hydraulically powered redundant winch on single fall. The davit system is suitable for semi-submersible or fixed platforms. The winch consist of a housing, grooved drum with integrated winch gears, holding brakes, accumulators, double constant speed devices, and hydraulic motor for “power on” operation.

The R-002 davit system provides:

- Launching of rescue boat in maximum load condition by means of hydraulic power
- Launching of the rescue boat based on stored mechanical power. Gravity lowering of the loaded rescue boat with double speed controllers.
- High speed retrieval of rescue boat
- Redundant retrieval system in case of power loss on primary unit
- Double limit stop devices
- Design verification, according to Norsok R-002

Several safety measures have been included in the design to achieve a redundancy of the davit system for on launching and recovery operations. No single failure shall result to unacceptable risk for operation of the system during MOB situations.

1. Dual operation mode:

The winch can operate in two modes

- “Power on” mode – normal operation.
- “Dead-ship” mode – operation in case of power loss.

2. Shock absorber system:

To reduce dynamic amplification, the davit is equipped with a damping cylinders directly on the wire routing. Damping cylinder system increases the time and length of stopping the load during emergency braking. It also reduces forces during re-entry and lowering under rough sea and conditions as stated in Norsok R-002.

3. Overload protection:

An overload relay in the starter cabinet prevents the davit from lifting loads in excess of the Safe Working Load.

4. Two holding brakes:

The winch is fitted with two independent hydraulic multi-disc brakes. The brakes can be engaged also during power loss.



5. Two constant speed devices:

Two hydraulic brake pumps controls the lowering motion and prevents free fall. If the primary hydraulic brake pump fails, the secondary brake pump will take over the braking load and maintain safe lowering speed.

6. Two accumulators:

Two bladder accumulators provide hydraulic pressure to release the holding brakes and lowering can be initiated. Each accumulator alone has the capacity of opening both holding brakes.

7. Push button controls and hydraulic joystick:

The davit system can be fully controlled by the supplied joystick stand. The joystick is equipped with start/stop button and emergency stop (mushroom type) for the HPU. The hydraulic joystick on the top provides full operability of the hydraulic frame and winch.

Launching and lowering of the rescue boat can also be initiated from within the rescue boat by dedicated swing out valve and control wire.

8. Redundant HPU

The hydraulic power unit is completely redundant with double electric motor, pump and control valve. Taking into account that the davit system is connected to both main and emergency mode of the vessel, the davit system is completely redundant for any operation.

9. Indication lamps

Indication lamps on the control cabinet, with AMP meter, overload protection alarm and LOW LOW oil level alarm.

10. Limit switches

There are two independent and of different make limit switch systems. The first barrier will automatically reduce the speed to approx.. 50% and the final barrier will stop motion totally when upper limit is reached.

2.2 WINCH AND WIRE

Type	NWR-40 NO winch
Drawing reference	A-60017
Wire rope type	Galvanized, rotation resistant (certified item)
Wire rope diameter, MBL and spec.	Ø 18 mm, MBL 240 kN, 1960N/mm ²
Inner / outer wire end	Secured to drum / Thimble and shackle
Shackle	Included
Master link w/handle	Included (certified item)

2.3. ELECTRICAL

Electric power supply	440V/3ph/60Hz (other on request)
Electrical cabinet	IP56
Remote control	IP56
Limit switch	IP56
Power consumption	67 kW (Main supply), 11 kW (Backup EOS supply)
Starting method	DOL - Direct on line
Duty rating	S6-40%
Motor space heating	Included, 40W, 230V
Electrical cabinet heating	Heat loss from 42V transformer
Wiring	Included, (only power supply cable required)
Transformer	Included, 440/42VAC (other on request)
Emergency stop	Yes, mushroom type
Ex Zone	Ex-proof, Zone II 2 G Ex de IIB T3

2.4. HYDRAULIC SYSTEM

System type	DIN 2353, cold formed tubing
Tubing material	AISI 316L
Fittings material	AISI 316L
Hose fittings material	AISI 316L

2.5. PAINTING SYSTEM

Blasting	SA 2.5
Specification	Norsok M-501
System	System 1
Total dry film thickness	280 µm

2.6. DOCUMENTATION

Technical specification davit	According to contract specification
General arrangement drawing	According to contract specification
Electrical wiring diagram	According to contract specification
Starter cabinet drawing	According to contract specification
Product certificate	According to contract specification
Lubrication oil chart	Viking Norsafe standard
Spareparts list	Viking Norsafe standard
Operation & Maintenance manual	Viking Norsafe standard
Installation manual	Viking Norsafe standard
Preservation & storage procedure	Viking Norsafe standard

3. PACKING

Format **Packed for transport in a 20 ft standard container**

4. OPTIONS

Note: Some options influence davit weight and performance, some option combinations may be incompatible. Maximum SWL must not be exceeded.

marking means to be supplied by maker, marking means not supplied by maker.

GENERAL DAVIT	
Additional manual handling crane for electric motors on HPU	<input type="checkbox"/>
Additional supports for lights, lanterns, starter cabinet etc.	<input type="checkbox"/>
Winterization / cold climate heating / canvas solutions	<input type="checkbox"/>
Commissioning performed by Viking Norsafe or Viking Norsafe Service Partners	<input type="checkbox"/>
Other options on request	<input type="checkbox"/>
ELECTRIC SYSTEM	
Voltage variation	<input type="checkbox"/>
Star Δ starting method	<input type="checkbox"/>
Additional electric cabinet heater	<input type="checkbox"/>
Alternative cabinet size / material / surface protection	<input type="checkbox"/>
PAINTING SPECIFICATION	
Other painting system and final color	<input type="checkbox"/>



VIKING Project No.: TBA
Rev. Date: 18.06.2013

VIKING Doc. No.: TSD-0024
Rev. No: 1

SPARE PARTS

Spare parts for Startup / Commissioning	<input type="checkbox"/>
Spare parts for Onboard spare	<input type="checkbox"/>
Spare parts for 1 year	<input type="checkbox"/>
Spare parts for 2 years	<input type="checkbox"/>

DOCUMENTATION

Factory acceptance test procedure	<input type="checkbox"/>
Factory acceptance test report	<input type="checkbox"/>
Inspection and test plan	<input type="checkbox"/>
Shipping, handling and lifting procedure	<input type="checkbox"/>
Packing & unpacking procedure	<input type="checkbox"/>
Commissioning procedure	<input type="checkbox"/>
TAG list	<input type="checkbox"/>
Winch drawing	<input type="checkbox"/>
Noise test report	<input type="checkbox"/>
Weight and COG datasheet	<input type="checkbox"/>
Weighing report/certificate	<input type="checkbox"/>
Other drawings/documentation/procedures	<input type="checkbox"/>

5. POSSIBLE BOAT FITTING THIS DAVIT SYSTEM

The VIKING Norsafe rescue boats fit the NDC-40 NO davit types and variants.

655 Mako

750 Magnum (Others on request)

6. YARD SUPPLY / RESPONSIBILITY

Transport	Depending on contract
Deck foundations / reinforcement	
Assembly, erection and welding to deck	
Wire installation on winch, routing on davit and termination	
All cables to starter cabinet and agreed interface	
Hydraulic oil filling of HPU	
Testing according to regulation after installation onboard	
Preservation and maintenance after davit arrived yard and installed	



VIKING Project No.: TBA

VIKING Doc. No.: TSD-0024

Rev. Date: 18.06.2013

Rev. No: 1