

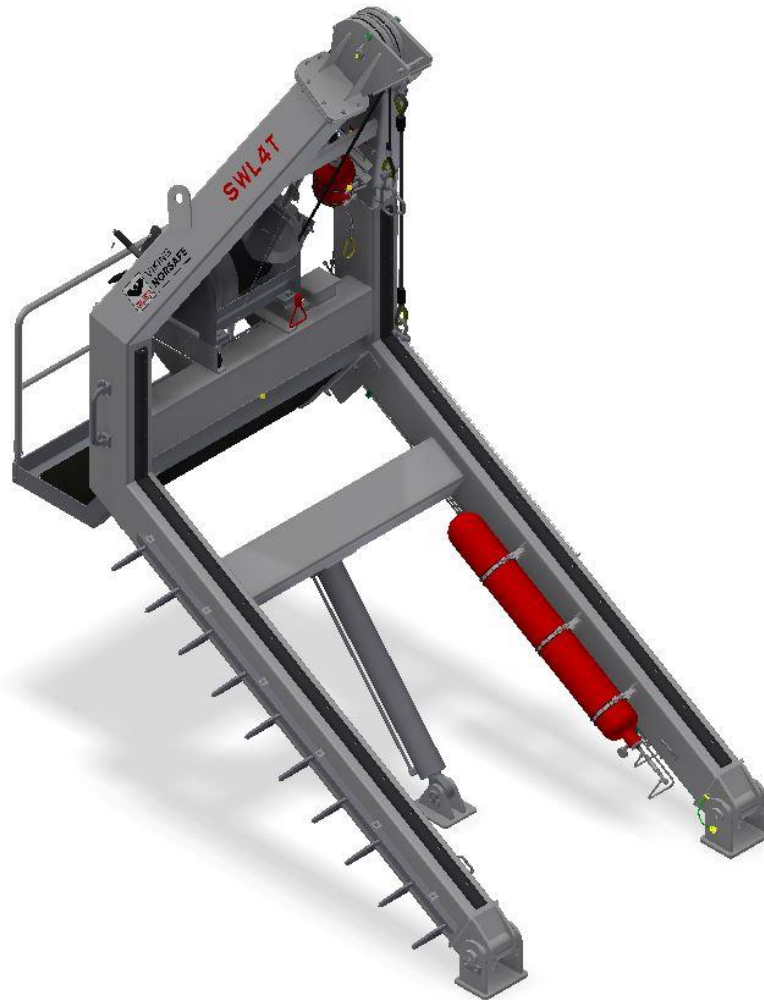

**VIKING
NORSAFE**
Boats and davits

Enterprise No.: NO940411696
www.VIKING-life.com

NDA-40 HST –Rescue Boat Davit



TECHNICAL SPECIFICATION

VIKING Norsafe Life-Saving Equipment Norway AS
Tybakken 90, N-4818 Faervik
P.O. Box 115, N-4852 Faervik
Arendal, Norway

VIKING Project No.: Standard

VIKING Doc. No.: TSD-0041

Rev. Date: 14.04.2020

Rev. No: 5

Tel: +47 37 05 85 00

Fax: +47 37 05 85 01

E-mail: VIKING-Norsafe@VIKING-life.com

1. REGULATION AND CERTIFICATION

Applicable rules and regulations In accordance with IMO/ SOLAS requirements, LSA Code and European Council Directive 2014/90/EU on Marine Equipment (MED)

Certificate	MED
Other certificate	Class certificate or flag acceptance on request

2. DAVIT SPECIFICATION

2.1. GENERAL DAVIT

Type	Rescue Boat Davit
Model	NDA-40 HST
Application	Rescue boat handling
Drawing reference	G-500668
Execution	High speed tension hydraulic pivoting davit (HST)
Boarding position	Inboard / Outboard on deck level
Operating position	From deck side and from inside the boat (Gravity lowering)
Davit system weight (Approx.)	3200 kg, davit incl. winch (dry weight)
Safe Working Load (SWL)	4000 kg
Trim / list conditions	10° / 20°
Max. lowering height	62.9 m (including 10°/20° trim/list condition)
Operation temperature	-20°C till +45°C (other range on request)
Min. hoisting speed	Hydraulically 48 m/min
Min. lowering speed	According to SOLAS regulation ($S = 0.4 + 0.02H$)
Manual hoisting	By manual hand-cranking
Pivot bearing type	Bronze bearings
Wire sheaves	Galvanized, equipped with ball bearings
Installation	3 (three) deck welding points (reduced installation time)
Deck reinforcement requirements	See general arrangement drawing
Davit system H / W / D	See general arrangement drawing
Deck space required	See general arrangement drawing

The Viking Norsafe NDA luffing davit system is especially designed for safe and efficient launching and retrieval of Viking Norsafe Rescue Boats. The davit system is designed for long time operation in a tough and corrosive marine/offshore environment and to fulfil all requirements as given in latest SOLAS/IMO requirements.

The system will allow:

- Hoisting and lowering of the fully loaded rescue boat up to 20° list and 10° trim.
- Gravity lowering of the fully loaded boat up to 20° list and 10° trim, completely independent of any power supply.
- An automatic high speed tensioning system (HST) and a dampening system on the davit to avoid wire from going slack in waves and large shocks coming to the davit and boat.



**VIKING
NORSAFE**

VIKING Project No.: Standard

VIKING Doc. No.: TSD-0041

Rev. Date: 14.04.2020

Rev. No: 5

The davit system consist of a pivoting A-frame that has a hydraulic cylinder and a hydraulically driven winch with single wire fall. The luffing and winch functions are driven by a single hydraulic power unit (HPU). The hydraulic system is equipped with a stored power unit (nitrogen accumulator) - which allows full operation of the davit in “dead ship” conditions.

The davit is designed to achieve optimum performance in terms of safety and reliability, and minimal maintenance levels. All selected equipment is chosen and installed to ensure the lowest possible emission of sound and for good access for service and repair.

A HPU is included, and must be located close to the davit. Hydraulic hoses are connected directly from HPU to davit. A separate control stand with a hydraulic joystick and remote control for start/stop of el motor on HPU is also included. The joystick is controlling two valves inside HPU by hydraulic remote hoses. The control stand has to be installed on deck in a suitable location where good visibility over the davit and boat is obtained.

A safety valve is installed in the hydraulic power unit. This safety valve prevents the davit from lifting loads in excess of the Safe Working Load, and protects the system and motor from being overloaded.

The winch is fitted with hydraulically operated, fail-safe multi-disc brake, which is fully oil submerged. In the event of hydraulic pressure loss, due to hose or connection failure, the brake will automatically activate and davit motion will stop.

For launching in dead ship conditions, stored power from accumulator and gravity lowering system in winch provides safe launching.

All internal hydraulic piping is properly done and completed on the entire davit system. The only installation work of piping required is the connection of the delivered five hydraulic hoses between the hydraulic power unit and the davit.

Starter cabinet is mounted on HPU as standard. All electrical cables for davit control, included 42V AC to rescue boat is installed and terminated by Viking Norsafe. Only main power supply is required.

The wave compensation system (tension system) is designed for recover a rescue boat in rough seas. For this action, the hoist rope has to be slightly tensioned during the recovery to avoid slack rope.

2.2 WINCH AND WIRE

Type	Zollern Hydraulic Winch ZR4.20
Drawing reference	DS-01129
Execution	Hydraulically hoisting and lowering / Gravity lowering / Manually hoisting / Manually fast hoisting
Brakes type	Negative multi-disk brakes, hydraulically operated
Wire rope type	Galvanized, rotation resistant (certified item)
Wire rope diameter, MBL and spec.	Ø 18 mm, MBL 236 kN, 1960N/mm ²
Inner / outer wire end	Secured to drum / Swaged eye
Connection shackle in thimble	Included (certified item)



2.3. ELECTRICAL

Electric power supply	440V/3ph/60Hz (other on request)
Electrical cabinet	IP56
Remote control	IP56
Limit switch	IP56
Power consumption	62.4 kW
Starting method	DOL - Direct on line
Duty rating	S6-40%
Motor space heating	Included, 40W
Wiring	Included, (only power supply cable required)
Cables type	Marine type, flame retardant halogen free
Transformer	Included, 440/42VAC (other on request)
Emergency stop	Yes, mushroom type

2.4. HYDRAULIC

Type	Independent integrated hydraulic system
Oil flow	120.0 l/min (at 50Hz and 60Hz)
Max. working pressure	280 bar
Oil amount	350 l
Motor type	250M-4 (at 50Hz); 225M-4 (at 60Hz)
Hydraulic cylinders	DS-00461 (Main cylinder), DS-00462 (Damping cylinder)
Hydraulic accumulators	1x Bladder type 10L & 1x Bladder type 40L
System fittings	ISO 8434-1 (DIN 2353) bite type fittings
Fittings and hose fittings	Zinc chromate Cr(VI)-free, secured with Denso tape
Tubes	AISI 316L

2.5. PAINTING SYSTEM

Blasting	SA 2.5
Specification	ISO 12944-5
System	Marine paint system (Jotun paint system)
Coating Two (2) layers (other on request)	Layer 1 Penguard universal, Alu - 220 µm Hardtop XP - 80 µm RAL 9016 (Traffic white)
Total dry film thickness	300 µm

2.6. DOCUMENTATION

Technical specification davit	According to contract specification
General arrangement drawing	According to contract specification
Hydraulic flow diagram	According to contract specification
HPU drawing	According to contract specification
Electrical wiring diagram	According to contract specification



Starter cabinet drawing	According to contract specification
Product certificate	According to contract specification
Lubrication oil chart	Viking Norsafe standard
Spareparts list	Viking Norsafe standard
Operation & Maintenance manual	Viking Norsafe standard
Installation manual	Viking Norsafe standard
Preservation & storage procedure	Viking Norsafe standard

3. PACKING

Format **Packed for transport in a 20 ft standard container**

4. OPTIONS

Note: Some options influence davit weight and performance, some option combinations may be incompatible. Maximum SWL must not be exceeded.

marking means to be supplied by maker, marking means not supplied by maker.

GENERAL DAVIT	
Support cradle for boat in stowed position	<input type="checkbox"/>
Embarkation platform/ladder for boat in stowed position	<input type="checkbox"/>
Anti-pendulum boat supports	<input type="checkbox"/>
Winterization / cold climate heating / canvas solutions	<input type="checkbox"/>
Commissioning performed by Viking Norsafe or Viking Norsafe Service Partners	<input type="checkbox"/>
Other options on request	<input type="checkbox"/>
ELECTRIC SYSTEM	
Voltage variation	<input type="checkbox"/>
Protection box for remote control	<input type="checkbox"/>
Ex-proof, Zone II 2 G Ex de IIB T3 (other on request)	<input type="checkbox"/>
Star Δ starting method	<input type="checkbox"/>
Additional electric cabinet heater	<input type="checkbox"/>
Alternative cabinet size / material / surface protection	<input type="checkbox"/>
HYDRAULIC SYSTEM	
Stainless steel fittings and hose fittings	<input type="checkbox"/>
Alternative HPU size / material / surface protection	<input type="checkbox"/>
HPU heater	<input type="checkbox"/>
PAINTING SPECIFICATION	
Norsok M-501 system (Viking Norsafe Doc. No. TSS-0030)	<input type="checkbox"/>
Other painting system and final color	<input type="checkbox"/>
SPARE PARTS	



**VIKING
NORSAFE**

VIKING Project No.: Standard

VIKING Doc. No.: TSD-0041

Rev. Date: 14.04.2020

Rev. No: 5

Spare parts for Startup / Commissioning	<input type="checkbox"/>
Spare parts for Onboard spare	<input type="checkbox"/>
Spare parts for 1 year	<input type="checkbox"/>
Spare parts for 2 years	<input type="checkbox"/>

DOCUMENTATION

Factory acceptance test procedure	<input type="checkbox"/>
Factory acceptance test report	<input type="checkbox"/>
Inspection and test plan	<input type="checkbox"/>
Shipping, handling and lifting procedure	<input type="checkbox"/>
Packing & unpacking procedure	<input type="checkbox"/>
Commissioning procedure	<input type="checkbox"/>
TAG list	<input type="checkbox"/>
Hydraulic flushing procedure	<input type="checkbox"/>
Winch drawing	<input type="checkbox"/>
Noise test report	<input type="checkbox"/>
Hydraulic flushing report	<input type="checkbox"/>
Weight and COG datasheet	<input type="checkbox"/>
Weighing report/certificate	<input type="checkbox"/>
Other drawings/documentation/procedures	<input type="checkbox"/>

5. POSSIBLE BOAT FITTING THIS DAVIT SYSTEM

The Viking Norsafe boats fit the NDA-40 HST davit types and variants.

Mako-655 MKI	Magnum-750
(Others on request)	



6. YARD SUPPLY / RESPONSIBILITY

Transport	Depending on contract
Deck foundations / reinforcement	
Assembly, erection and welding to deck	
Wire routing on davit and termination	
Hydraulic piping between HPU unit, davit and control stand	
All cables to starter cabinet and agreed interface	
Hydraulic oil filling	
Testing according to regulation after installation onboard	
Preservation and maintenance after davit arrived yard and installed	