

Mounting instruction for VIKING Double Sliding Rack

V-MI- 0182



Installation davit launchable liferaft on double sliding rack With HAMMAR or SeaMate hydrostatic release unit

- 1 Container closing bands
- 2 Lashing strap
- 3 Rack
- 4 HAMMAR or SeaMate release unit
- 5 Painter line
- 6 Shackle
- 7 Lacing
- 8 Quick release pocket
- 9 Container flap

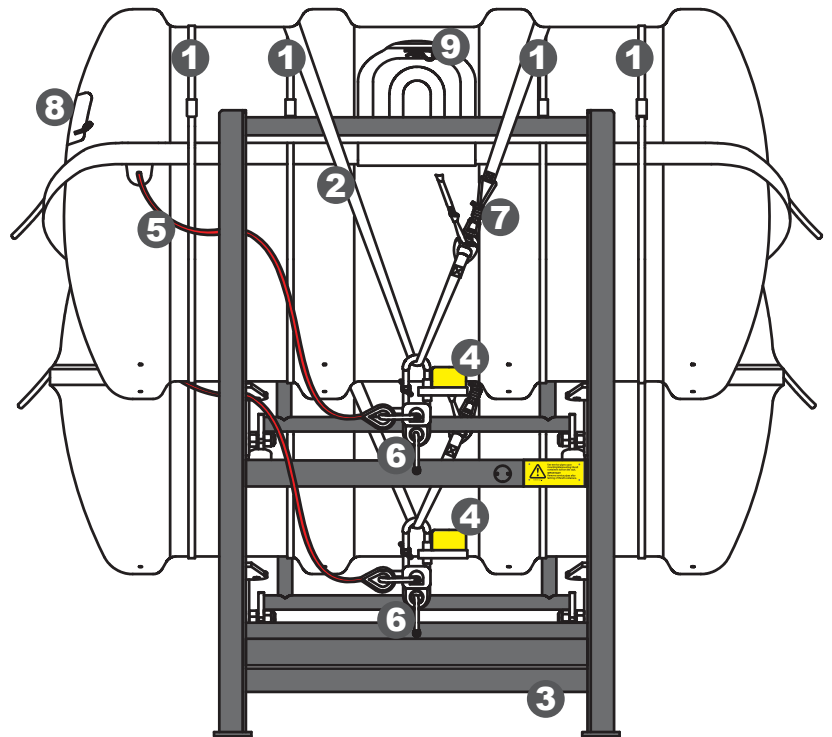

HAMMER release unit



SeaMate release unit



Cell rubber on all surfaces facing the container.

- A** = Holder for service pipe
- B** = Fastening point for lashing strap
- C** = Cell rubber on rack profile
- D** = U-Bar

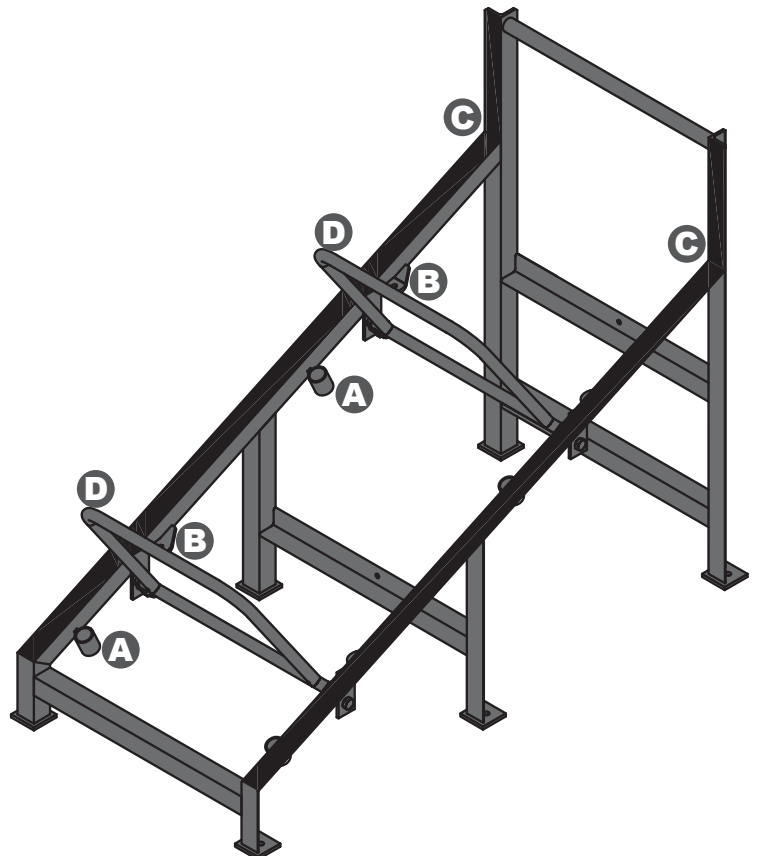

Mounting instruction for VIKING Double Sliding Rack

V-MI- 0182



Sliding Racks

Installation

Install container in rack on the deck by means of either bolting or welding.

1. Place the service pipes in the holders for service pipes.
2. Shackle the lashing straps to the fastening points leading the lashing underneath the supporting frame of the rack.
3. Place the container on the rack resting on the service pipes.
4. Attach the HRU (hydrostatic release unit) to the ramp, following instructions in page 4.
5. Lead the lashing strap over the top of the container so the U-Bar is pressed against the container. Connect the lashing to the HRU following instruction on the last page, be aware lashing not obstruct container flap.
6. Tilt container no. 1 about 15-20° from vertical to avoid top bar of the ramp obstruct the container flap when operating.

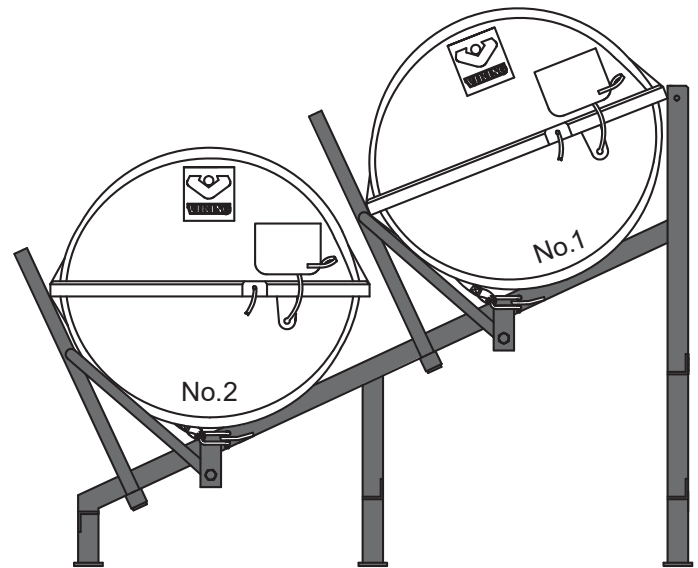

Positioning

- Liferrafts should not rest on each other.
- Liferrafts should be oriented with draining holes straight down.
- To avoid complication during deployment, liferafts should not be blocked by chains, railing or similar.

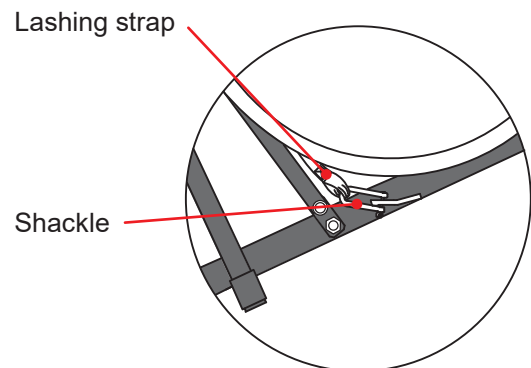

Lashing

- Lashing should always be centered to ensure a straight pull, and should always be tightly fastened.
- Release hook should be installed easy to reach and operate.
- Lashing must not be intertwined.

Painter Line

- Painter line should be positioned in straightest possible line without being intertwined in the rack.
- If painter line is too long tape it to the container.
- Eyelink should always be tucked in and not be pulled out.

Mounting instruction for VIKING Double Sliding Rack

V-MI- 0182



Use 6 mm. line. Fasten it with bow knots and lead the line through both lashings approx. 3-4 times. Finish off with 2 times clove hitches.

Position the lacing above the U-Bar to prevent the lashings from slipping off the container's rib and to avoid obstructing the container flap.

Lacing control lashings position

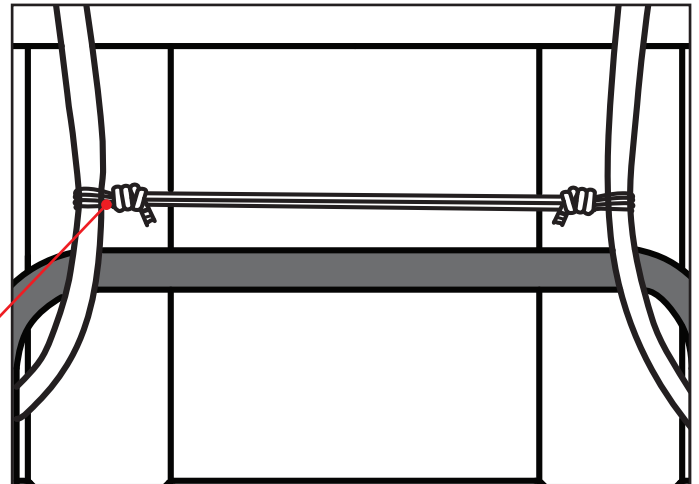

Lashing lead through U-Bar

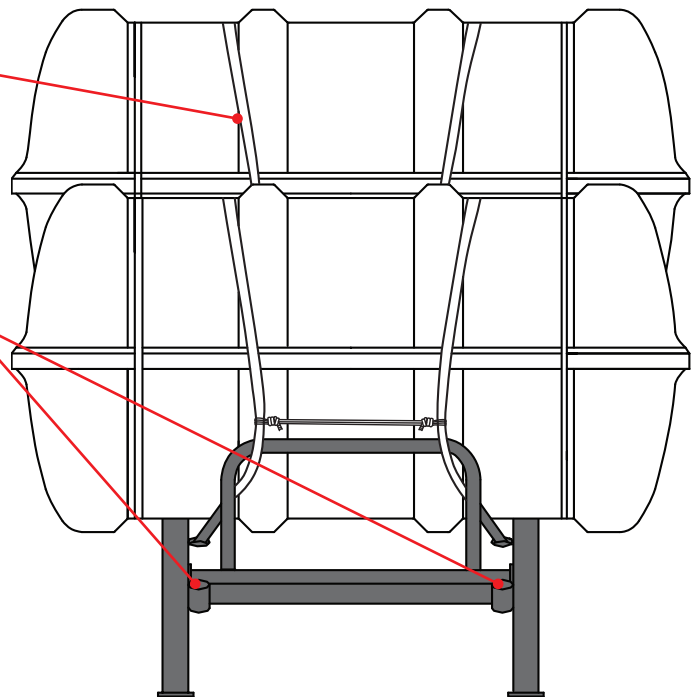

Note:

Lines, cords and lashings must be replaced if they have become frayed, damaged or decomposed.

Mounting instruction for VIKING Double Sliding Rack

V-MI- 0182



Mounting Instruction

Hydrostatic release unit type Hammar

- 1 Lashing strap left side
Lashing strap right side
- 2 Red line for release
of sliphook
- 3 Sliphook
- 4 Lacing fastening line by means
of bow knots and lead the line
through both loops approx. 5-6
times and finish off with 2 times
clove hitches
- 5 Shackle
- 6 Liferaft painter line
- 7 Hammar hydrostatic
release unit.
- 8 Weak link
- 9 Rack

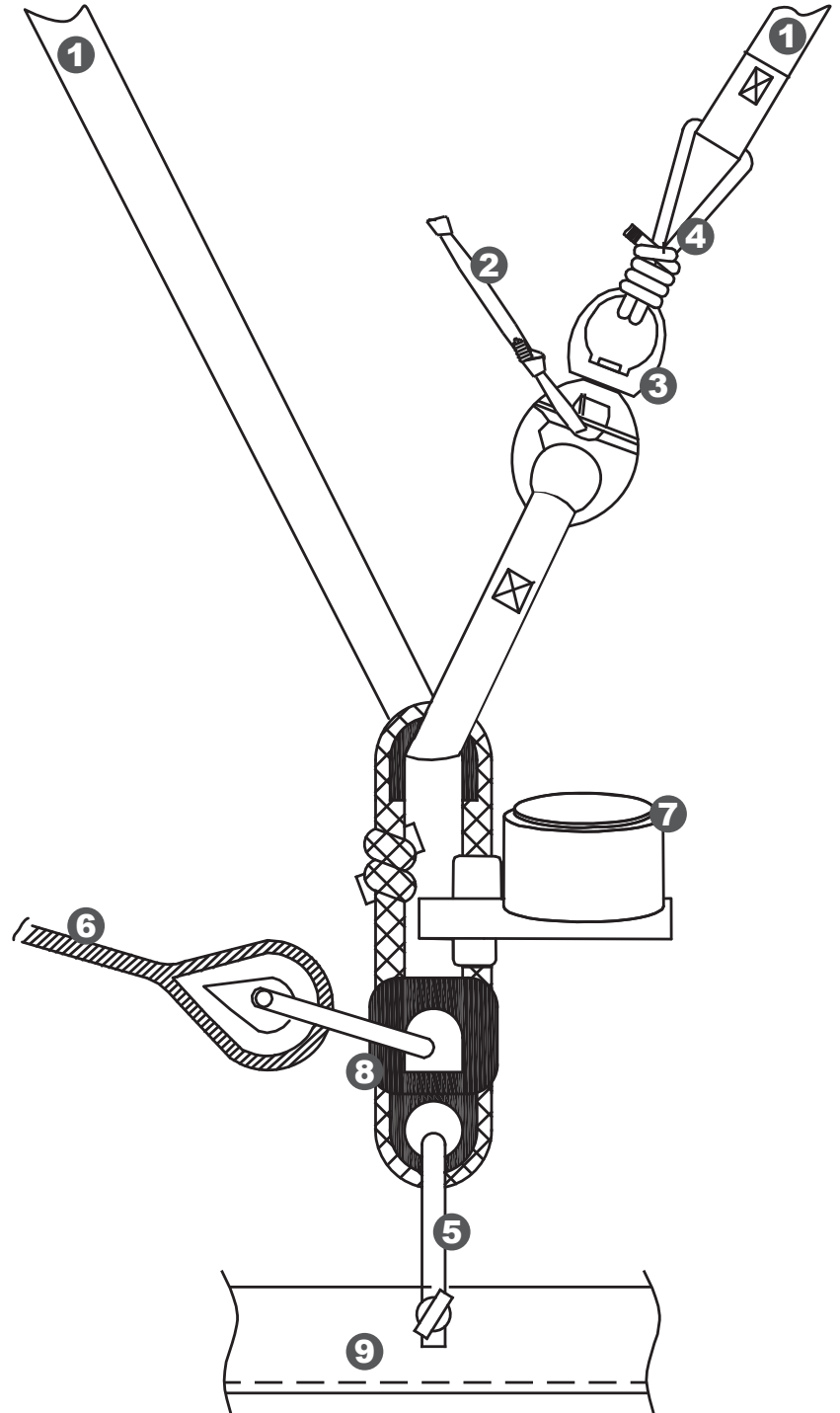

Mounting instruction for VIKING Double Sliding Rack

V-MI- 0182



Maintenance of Hooks and Lashing

This instruction is to help to control and maintain lashings of liferafts, that are not part of the Marine Evacuation System.

Lashing

The lashing of liferafts should be tight. Over the years they can start to rot, therefore you might have to change these.

Lashings have an approximate lifetime of 10 years. Lashings produced from 2018 forward are marked with expiration date, making it easier to plan replacement.



Lashing

Hook

VIKING has two types of hooks, Pelican hooks and Slip hooks.

Both are made of corrosive resistant material, but on rare occasions corrosion may be found.

Both can be maintained by greasing with GREASE OMEGA 66, Material no.1012028 or Anti-corrosion wax based treatment advised by VIKING. Long-time protection of steel parts. Apply the corrosion protection on the surface with a brush. Wipe off all excessive wax without removing the wax from moving parts.

Ensure to replace when corrosion is observed, or let it be fixed by the servicing station, when liferaft is in for service.

All spare parts can be purchased through the VIKING Servicing Network.



Pelican hook



Slip hook