



# DREWIL ENTERSHIP

---

MAINTENANCE, USE,  
INSPECTION AND  
INSPECTION MANUAL

## **PILOT LADDERS AND EMBARKATION LADDERS**

---

The captain, officers and the crew of the vessel, as users of the pilot ladders and embarkation ladders on board the vessel, are required to comply with these instructions.

In accordance with the requirements of ISO 799-2: 2021 (E) as a supplement to ISO 799-1: 2019 (E) according to the following points and tables:

Follow points 3, 4, 5, 6, 7, 8, 9 of ISO 799-2: 2021 (E).

Follow Annex B and its points B1, B2, B3, B4.

Tables A1, A2, A3, A4 should be completed according to the relevant time periods specified in the tables.

If you need to replace the step of the ladder, use the enclosed Replacement step user manual.



A pilot ladder pre-use inspection shall be completed by a deck officer prior to each use. See Table A.1 for an example checklist.

**Table A.1 — Pre-use inspection**

Date:		Pilot ladder identification number:	
Pilot ladder pre-use inspection to be carried out by a deck officer.			
1	Consult manufacturer's maintenance and use instructions prior to carrying out this inspection. Does the ladder have a certificate of compliance from the manufacturer?	<input type="checkbox"/> Yes	<input type="checkbox"/> No
2	Has the ladder been in service more than 30 months? (If so, has it been recertified?)	<input type="checkbox"/> Pass	<input type="checkbox"/> Fail
3	Steps and spreader steps are horizontal and evenly spaced (330 mm +/- 20 mm between steps), and free of paint, protective coatings or dirt that will inhibit non-slip capability of the steps.	<input type="checkbox"/> Yes	<input type="checkbox"/> No
4	Side ropes are clean and in serviceable condition. No knots splices or joins except above the top step. List any visible damage: _____	<input type="checkbox"/> Pass	<input type="checkbox"/> Fail
5	Steps are not cracked/broken or bent/warped or worn. Steps are clean and free of paint.	<input type="checkbox"/> Yes	<input type="checkbox"/> No
6	Step fixtures are secure and tight.	<input type="checkbox"/> Yes	<input type="checkbox"/> No
7	Seizings/step securing are in good condition.	<input type="checkbox"/> Yes	<input type="checkbox"/> No
8	Number of replacement steps (maximum of 2): _____	<input type="checkbox"/> Pass	<input type="checkbox"/> Fail
9.	The result of this inspection is recorded in the following location: _____	<input type="checkbox"/> Yes	
10	Conduct risk assessment prior to rigging pilot ladder.	<input type="checkbox"/> Yes	
11	Man ropes: (28 to 32) mm manila man-ropes are available if requested by the pilot. Man-ropes are free of knots, joins and splices, and are in serviceable condition.	<input type="checkbox"/> Yes	<input type="checkbox"/> No <input type="checkbox"/> N/A
This ladder is fit for use. <input type="checkbox"/> YES <input type="checkbox"/> NO			
Name and rank of officer performing the inspection: _____			
Signed by master: _____			

A pilot ladder post-use inspection shall be completed by a deck officer after each use. See Table A.2 for an example checklist.

**Table A.2 — Post-use inspection**

Date:		Pilot ladder identification number:	
Pilot ladder post-use inspection to be carried out by a deck officer.			
1	Consult manufacturer's maintenance and use instructions prior to carrying out this inspection.	<input type="checkbox"/> Yes	<input type="checkbox"/> No
2	Steps are horizontal and evenly spaced (330 mm +/- 20 mm between steps).	<input type="checkbox"/> Yes	<input type="checkbox"/> No
3	Side ropes are clean and in serviceable condition. No knots splices or joins except above the top step. List any visible damage: _____ _____	<input type="checkbox"/> Pass	<input type="checkbox"/> Fail
4	Steps are not cracked/broken or bent/warped or worn. Steps are clean and free of paint, protective coatings or dirt that will inhibit the non-slip capability of the steps.	<input type="checkbox"/> Yes	<input type="checkbox"/> No
5	Step fixtures are secure and tight.	<input type="checkbox"/> Yes	<input type="checkbox"/> No
6	Seizings/step securing are in good condition.	<input type="checkbox"/> Yes	<input type="checkbox"/> No
7	Number of replacement steps (maximum of 2): _____	<input type="checkbox"/> Pass	<input type="checkbox"/> Fail
8	The result of this inspection is recorded in the following location: _____	<input type="checkbox"/> Yes	
9	The ladder is stored in accordance with the manufacturer instructions.	<input type="checkbox"/> Yes	
This ladder is fit for ongoing use. <input type="checkbox"/> YES <input type="checkbox"/> NO			
Name and rank of officer performing inspection: _____			
Signed by master: _____			

A three-monthly inspection shall be carried out by a senior deck officer. See Table A.3 for an example checklist. This officer should be assisted by a suitably experienced crew member with experience and training in inspecting pilot ladders. Results shall be recorded and kept in accordance with [Clause 7](#).

**Table A.3 — Three-monthly inspection**

Date:		Pilot ladder identification number:	
Pilot ladder three-monthly inspection to be carried out by a senior deck officer.			
1	Consult manufacturer’s maintenance and use instructions prior to carrying out this inspection.	<input type="checkbox"/> Yes	<input type="checkbox"/> No
2	Does the ladder have a manufacturer’s certificate? Has the ladder been in service more than 30 months? (If so, has it been recertified?)	<input type="checkbox"/> Pass	<input type="checkbox"/> Fail
3	Steps are horizontal and evenly spaced (330 mm +/- 20 mm between steps).	<input type="checkbox"/> Yes	<input type="checkbox"/> No
4	Side ropes are clean and in serviceable condition. No knots splices or joints (except above the top step if manufactured in that manner.) Refer to the manufacturer’s written instructions. List any visible damage: _____ _____	<input type="checkbox"/> Pass	<input type="checkbox"/> Fail
5	Steps are not cracked/broken or bent/warped or worn. Steps are clean and free of paint, protective coatings or dirt that will inhibit the non-slip capability of the steps.	<input type="checkbox"/> Yes	<input type="checkbox"/> No
6	Number of replacement steps (maximum of 2): _____	<input type="checkbox"/> Pass	<input type="checkbox"/> Fail
7	Step fixtures are secure and tight.	<input type="checkbox"/> Yes	<input type="checkbox"/> No
8	Seizings/step securing are in good condition	<input type="checkbox"/> Yes	<input type="checkbox"/> No
9	Storage: is the pilot ladder stored in accordance with the manufacturer’s instructions?	<input type="checkbox"/> Yes	<input type="checkbox"/> No
10	The result of this inspection recorded in the following location: _____ _____	<input type="checkbox"/> Yes	
This ladder is fit for ongoing use.			
Name and rank of senior officer performing inspection: _____			
Signed by master: _____			

There shall be an annual inspection by the flag State or Classification Society surveyor. See Table A.4 for an example checklist. The flag State or Classification Society can use its own checklist. Results shall be recorded as required by [Clause 7](#).

**Table A.4 — Annual inspection**

Date:		Pilot ladder identification number:
Pilot ladder annual inspection carried out by flag State or Classification Society surveyor.		
1	Review inspection records of pilot ladders. Date of entry into service: _____ If the service life is greater than 30 months, review test records in accordance with <a href="#">6.6</a> .	<input type="checkbox"/> Pass <input type="checkbox"/> Fail
2	Are the manufacturer's instructions for maintenance and use available onboard?	<input type="checkbox"/> Yes <input type="checkbox"/> No
3	Is the ladder stored in accordance with the manufacturer's care and maintenance instructions? Notes: _____	<input type="checkbox"/> Yes <input type="checkbox"/> No
4	Are steps horizontal and evenly spaced (330 mm +/- 20 mm between steps)?	<input type="checkbox"/> Yes/Pass <input type="checkbox"/> No/Fail
5	Steps are not cracked/broken or bent/warped or worn. Steps are clean and free of paint, protective coatings or dirt that will inhibit the non-slip capability of the steps. Timber steps are free of knots.	<input type="checkbox"/> Pass <input type="checkbox"/> Fail
6	Number of replacement steps (maximum of 2): _____ Have the replacement steps been fitted as per manufacturer's instructions?	<input type="checkbox"/> Pass <input type="checkbox"/> Fail
7	Step fixtures are secure and tight.	<input type="checkbox"/> Pass <input type="checkbox"/> Fail
8	Side ropes are in good condition, refer to the manufacturer's instructions for the inspection of the side ropes.	<input type="checkbox"/> Pass <input type="checkbox"/> Fail
9	Seizings/step securing are in good condition, pay particular attention to the termination below the bottom step. Is the side rope tightly wound around a step fixture or fitted with a double seizing and suitably whipped to prevent fraying?	<input type="checkbox"/> Pass <input type="checkbox"/> Fail
10	The ladder is fitted with a legible identification plate below the top step and lowest spreader.	<input type="checkbox"/> Pass <input type="checkbox"/> Fail
11	The result of this inspection recorded in the following location: _____	<input type="checkbox"/> Yes
I hereby certify the above pilot ladder is fit for ongoing use: Name: _____ Classification Society or Inspector's employer: _____ Signed by master: _____		

---

---

**Ships and marine technology — Pilot  
ladders —**

Part 2:  
**Maintenance, use, survey, and  
inspection**

*Navires et technologie maritime — Échelles de pilote —  
Partie 2: Maintenance, utilisation, étude et inspection*



Authorized users of Pilot and Embarkation ladders only



**COPYRIGHT PROTECTED DOCUMENT**

© ISO 2021

All rights reserved. Unless otherwise specified, or required in the context of its implementation, no part of this publication may be reproduced or utilized otherwise in any form or by any means, electronic or mechanical, including photocopying, or posting on the internet or an intranet, without prior written permission. Permission can be requested from either ISO at the address below or ISO's member body in the country of the requester.

ISO copyright office  
CP 401 • Ch. de Blandonnet 8  
CH-1214 Vernier, Geneva  
Phone: +41 22 749 01 11  
Email: [copyright@iso.org](mailto:copyright@iso.org)  
Website: [www.iso.org](http://www.iso.org)

Published in Switzerland

# Contents

	Page
Foreword .....	iv
Introduction .....	v
<b>1 Scope</b> .....	<b>1</b>
<b>2 Normative references</b> .....	<b>1</b>
<b>3 Terms and definitions</b> .....	<b>1</b>
<b>4 Inspection of ladders</b> .....	<b>1</b>
<b>5 Care and maintenance instructions</b> .....	<b>2</b>
<b>6 Maintenance</b> .....	<b>3</b>
<b>7 Records</b> .....	<b>3</b>
<b>8 Storage</b> .....	<b>4</b>
<b>9 Use</b> .....	<b>4</b>
<b>Annex A (normative) Inspection intervals, with examples of checklists</b> .....	<b>5</b>
<b>Annex B (informative) Rope ladders — Care and maintenance</b> .....	<b>9</b>
<b>Bibliography</b> .....	<b>14</b>

## Foreword

ISO (the International Organization for Standardization) is a worldwide federation of national standards bodies (ISO member bodies). The work of preparing International Standards is normally carried out through ISO technical committees. Each member body interested in a subject for which a technical committee has been established has the right to be represented on that committee. International organizations, governmental and non-governmental, in liaison with ISO, also take part in the work. ISO collaborates closely with the International Electrotechnical Commission (IEC) on all matters of electrotechnical standardization.

The procedures used to develop this document and those intended for its further maintenance are described in the ISO/IEC Directives, Part 1. In particular, the different approval criteria needed for the different types of ISO documents should be noted. This document was drafted in accordance with the editorial rules of the ISO/IEC Directives, Part 2 (see [www.iso.org/directives](http://www.iso.org/directives)).

Attention is drawn to the possibility that some of the elements of this document may be the subject of patent rights. ISO shall not be held responsible for identifying any or all such patent rights. Details of any patent rights identified during the development of the document will be in the Introduction and/or on the ISO list of patent declarations received (see [www.iso.org/patents](http://www.iso.org/patents)).

Any trade name used in this document is information given for the convenience of users and does not constitute an endorsement.

For an explanation of the voluntary nature of standards, the meaning of ISO specific terms and expressions related to conformity assessment, as well as information about ISO's adherence to the World Trade Organization (WTO) principles in the Technical Barriers to Trade (TBT), see [www.iso.org/iso/foreword.html](http://www.iso.org/iso/foreword.html).

This document was prepared by Technical Committee ISO/TC 8, *Ships and marine technology*, Subcommittee SC 1, *Maritime safety*.

A list of all parts in the 799 series can be found on the ISO website.

Any feedback or questions on this document should be directed to the user's national standards body. A complete listing of these bodies can be found at [www.iso.org/members.html](http://www.iso.org/members.html).

## Introduction

This document supplements the IMO requirements for pilot ladders, since IMO instruments do not include specific requirements for manufacturers to supply guidance on maintenance, storage and use of pilot ladders. The inclusion of this guidance was considered necessary in order to ensure that pilot ladders are kept in a condition consistent with the requirements of IMO instruments and ISO 799-1.

For use by authorized users of Pilot and Embarkation ladders only



# Ships and marine technology — Pilot ladders —

## Part 2: Maintenance, use, survey, and inspection

### 1 Scope

This document provides requirements and recommendations for the maintenance, use, storage, and inspection of pilot ladders.

### 2 Normative references

The following documents are referred to in the text in such a way that some or all of their content constitutes requirements of this document. For dated references, only the edition cited applies. For undated references, the latest edition of the referenced document (including any amendments) applies.

ISO 9554:2019, *Fibre ropes — General specifications*

ISO/IEC Guide 37, *Instructions for use of products by consumers*

ISO 799-1:2019, *Ships and marine technology — Pilot ladders — Part 1: Design and specification*

### 3 Terms and definitions

For the purposes of this document, the following terms and definitions apply.

ISO and IEC maintain terminological databases for use in standardization at the following addresses:

- ISO Online browsing platform: available at <https://www.iso.org/obp>
- IEC Electropedia: available at <http://www.electropedia.org/>

#### 3.1

##### **user**

ship's master, officers and crew who operate a ship on a day-to-day basis

#### 3.2

##### **deck officer**

deck crew certificated in accordance with the STCW Convention

#### 3.3

##### **senior deck officer**

deck crew certificated in accordance with the STCW Convention and performing the duties of chief officer or master

#### 3.4

##### **spreader step**

step no less than 1,8 m long to prevent the pilot ladder from twisting

### 4 Inspection of ladders

The vessel's planned maintenance procedures shall include requirements for the inspection and maintenance of pilot ladders that comply with this document.

The ladders shall be inspected before and after each use by a deck officer. Additionally, a senior deck officer shall inspect the ladders at three-month intervals. Ladders shall also be inspected annually by a classification society surveyor or authorized representative of the vessel's flag State.

## 5 Care and maintenance instructions

The manufacturer of a pilot ladder shall supply care and maintenance instructions to users. These instructions shall be produced in accordance with ISO/IEC Guide 37.

The following are the minimum instructions required.

- a) Instructions for inspecting the ladder before and after use. A sample checklist for such inspections is contained in [Annex A](#).
- b) Instructions on detailed periodic inspection and a list of people authorised to conduct this inspection. The minimum time between these inspections and the qualification of persons carrying out these inspections shall be in accordance with the sample checklist for such inspections. Examples are contained in [Annex A](#). A Classification Society can use its alternative checklist in lieu of [Annex A](#).
- c) Specific instructions on inspecting the side ropes; i.e. how to inspect manila or other types of rope used, and factors to be taken into account when determining suitability for ongoing use. These instructions shall be in accordance ISO 9554:2019, Annex C.
- d) Specific instructions on inspecting and repairing rope seizings or securing devices.
- e) List of repairs that can be conducted by users without the need for recertification.
- f) Care and storage instructions with specific warning on the proximity to chemicals, effect of sunlight or other possible causes of degradation of the ladder, e.g. potential effect of different cargo types on ladders longevity, effect of being stored wet. These instructions shall take into account ISO 9554:2010, Annex A.
- g) Factors that would shorten the life of the pilot ladder, e.g. passing over sharp coamings or small diameter bends, different methods used to secure the ladder to the deck, such as shackles around side ropes.
- h) Acceptable and unacceptable method(s) of securing the ladder to strong points, e.g. the use of iron deck tongues is an unacceptable method of securing pilot ladders to the deck.
- i) Pictorial examples of damage or conditions under which the ladder shall be withdrawn from service. A detailed written description shall be included with these examples.
- j) Expected service life of the pilot ladder, which may be less than 30 months, particularly on ladders where side ropes cannot be inspected due to the use of mechanically applied metal clamps.
- k) Inspections shall be carried out at the intervals stated in [Annex A](#).
- l) Care and maintenance of rope pilot ladders shall be in accordance with this clause and should follow the recommendations of [Annex B](#).

## 6 Maintenance

**6.1** Damaged steps shall be replaced with replacement steps meeting the requirements of ISO 799-1:2019, Clause 4 and subclause 5.18. The replacement steps shall be of the type supplied or specified by the ladder manufacturer. A ladder shall not include more than two replacement steps. These steps shall not be next to each other.

**6.1.1** Replacement steps shall be fitted by the manufacturer or the manufacturer's approved repair facility, a facility approved by the flag State or a Classification Society. Records shall be maintained of replacement steps in accordance with [Clause 7](#).

**6.2** If a ladder requires a third replacement step, it shall be rebuilt and recertified by the manufacturer or the manufacturer's approved repair facility.

**6.3** A ladder constructed with spun thermoset polyester side ropes, with polypropylene core of contrasting colour with the inner core showing at any place throughout the length of the ladder, is no longer serviceable and the ladder shall be removed from service or scrapped.

**6.4** Where a manufacturer allows replacement steps to be fitted, the manufacturer shall supply:

- two replacement steps;
- one replacement spreader step;
- step fixtures to allow repair to be carried out;
- instructions for fitting replacement steps and spreader step.

**6.5** Where a manufacturer allows small repairs such as replacements of rope seizings or replacements of step fixtures, the manufacturer shall supply the seizing material and spare step fixtures.

**6.6** Each ladder shall be subjected to the ladder and step attachment strength test in ISO 799-1:2019, Table 2, at intervals of not more than 30 months. The ladder shall be stamped or tagged under the lowest spreader step and the top step with the date of the test and the identification of the person or company performing the test. The person or company performing the test shall also provide a test certificate to the master indicating the details of the test, including the date and the identification of the person or company performing the test. Each ladder which fails the test shall be rebuilt according to ISO 799-1:2019, 10.3, or scrapped.

## 7 Records

The ship's master shall maintain records relating to the pilot ladders. These records shall be available for inspection on request of the port state control officer, class surveyor, flag state, port authority, or marine pilot.

These records shall include:

- a) the pilot ladder serial number or identity number;
- b) a certificate of compliance from the manufacturer;
- c) the date of receipt onboard;
- d) the dates when the pilot ladder was put into service and withdrawn from service;

- e) the date of detailed inspections and the person performing the inspections;
- f) any findings;
- g) the repairs carried out;
- h) records of any steps replaced;
- i) records as required by [9.3](#).

## 8 Storage

Pilot ladders shall be kept clean and properly stowed in accordance with the manufacturer's care and maintenance instructions. Pilot ladders shall not be permanently rigged, they shall be derigged after each use and stowed in accordance with this document.

## 9 Use

**9.1** The safety of a person suspended over the ship's side on a pilot ladder is dependent on the material state of the ladder and on personnel maintaining a firm hold on that structure. Accordingly, the use of a pilot ladder by a pilot or other persons should be treated as a safety critical activity.

Pilot ladders should only be used for embarkation and disembarkation of personnel and should never be used for any other purpose such as draught readings or any maintenance work.

**9.2** Personnel performing inspections on pilot ladders should take a "safety first" approach to determine the suitability for ongoing use. If there is any doubt the pilot ladder shall not be used. Pilot ladders not complying with all parts of this document shall not be used.

**9.3** The rigging and derigging of pilot ladders is considered a safety critical activity. Operators shall perform risk assessment. This risk assessment shall include, but not be limited to, the rigging and derigging process. Records of risk assessment shall be maintained in accordance with the requirements of the vessel's safety management system.

**9.4** The use of pilot ladders to embark and disembark ships is considered a safety critical activity. Organizations employing personnel who board and disembark vessels by pilot ladders shall perform a risk assessment for such operations.

**9.5** Personnel responsible for rigging and inspecting pilot ladders shall receive periodic training in the inspection requirements, regulations and standards associated with pilot ladders and their use.

Where other arrangements or equipment are essential for use in conjunction with a pilot ladder, those arrangements or equipment shall be included in such training. This requirement may be fulfilled by the use of an onboard computer-based training module.

**9.6** For the IMO required boarding arrangements for pilots, see Reference [\[3\]](#).

## Annex A (normative)

### Inspection intervals, with examples of checklists

This annex specifies inspection intervals. It also provides examples of checklists for manufacturers' consideration when developing such checklists, as required by Clause 5.

A pilot ladder pre-use inspection shall be completed by a deck officer prior to each use. See Table A.1 for an example checklist.

**Table A.1 — Pre-use inspection**

Date:	Pilot ladder identification number:	
Pilot ladder pre-use inspection to be carried out by a deck officer.		
1	Consult manufacturer's maintenance and use instructions prior to carrying out this inspection. Does the ladder have a certificate of compliance from the manufacturer?	<input type="checkbox"/> Yes <input type="checkbox"/> No
2	Has the ladder been in service more than 30 months? (If so, has it been recertified?)	<input type="checkbox"/> Pass <input type="checkbox"/> Fail
3	Steps and spreader steps are horizontal and evenly spaced (330 mm +/- 20 mm between steps), and free of paint, protective coatings or dirt that will inhibit non-slip capability of the steps.	<input type="checkbox"/> Yes <input type="checkbox"/> No
4	Side ropes are clean and in serviceable condition. No knots splices or joins except above the top step. List any visible damage: _____ _____	<input type="checkbox"/> Pass <input type="checkbox"/> Fail
5	Steps are not cracked/broken or bent/warped or worn. Steps are clean and free of paint.	<input type="checkbox"/> Yes <input type="checkbox"/> No
6	Step fixtures are secure and tight.	<input type="checkbox"/> Yes <input type="checkbox"/> No
7	Seizings/step securing are in good condition.	<input type="checkbox"/> Yes <input type="checkbox"/> No
8	Number of replacement steps (maximum of 2): _____	<input type="checkbox"/> Pass <input type="checkbox"/> Fail
9.	The result of this inspection is recorded in the following location: _____ _____	<input type="checkbox"/> Yes
10	Conduct risk assessment prior to rigging pilot ladder.	<input type="checkbox"/> Yes
11	Man ropes: (28 to 32) mm manila man-ropes are available if requested by the pilot. Man-ropes are free of knots, joins and splices, and are in serviceable condition.	<input type="checkbox"/> Yes <input type="checkbox"/> No <input type="checkbox"/> N/A
This ladder is fit for use. <input type="checkbox"/> YES <input type="checkbox"/> NO		
Name and rank of officer performing the inspection: _____		
Signed by master: _____		

A pilot ladder post-use inspection shall be completed by a deck officer after each use. See Table A.2 for an example checklist.

**Table A.2 — Post-use inspection**

Date:		Pilot ladder identification number:	
Pilot ladder post-use inspection to be carried out by a deck officer.			
1	Consult manufacturer’s maintenance and use instructions prior to carrying out this inspection.	<input type="checkbox"/> Yes	<input type="checkbox"/> No
2	Steps are horizontal and evenly spaced (330 mm +/- 20 mm between steps).	<input type="checkbox"/> Yes	<input type="checkbox"/> No
3	Side ropes are clean and in serviceable condition. No knots splices or joins except above the top step. List any visible damage: _____ _____	<input type="checkbox"/> Pass	<input type="checkbox"/> Fail
4	Steps are not cracked/broken or bent/warped or worn. Steps are clean and free of paint, protective coatings or dirt that will inhibit the non-slip capability of the steps.	<input type="checkbox"/> Yes	<input type="checkbox"/> No
5	Step fixtures are secure and tight.	<input type="checkbox"/> Yes	<input type="checkbox"/> No
6	Seizings/step securing are in good condition.	<input type="checkbox"/> Yes	<input type="checkbox"/> No
7	Number of replacement steps (maximum of 2): _____	<input type="checkbox"/> Pass	<input type="checkbox"/> Fail
8	The result of this inspection is recorded in the following location: _____	<input type="checkbox"/> Yes	
9	The ladder is stored in accordance with the manufacturer instructions.	<input type="checkbox"/> Yes	
This ladder is fit for ongoing use. <input type="checkbox"/> YES <input type="checkbox"/> NO			
Name and rank of officer performing inspection: _____			
Signed by master: _____			

A three-monthly inspection shall be carried out by a senior deck officer. See Table A.3 for an example checklist. This officer should be assisted by a suitably experienced crew member with experience and training in inspecting pilot ladders. Results shall be recorded and kept in accordance with [Clause 7](#).

**Table A.3 — Three-monthly inspection**

Date:		Pilot ladder identification number:	
Pilot ladder three-monthly inspection to be carried out by a senior deck officer.			
1	Consult manufacturer’s maintenance and use instructions prior to carrying out this inspection.	<input type="checkbox"/> Yes	<input type="checkbox"/> No
2	Does the ladder have a manufacturer’s certificate? Has the ladder been in service more than 30 months? (If so, has it been recertified?)	<input type="checkbox"/> Pass	<input type="checkbox"/> Fail
3	Steps are horizontal and evenly spaced (330 mm +/- 20 mm between steps).	<input type="checkbox"/> Yes	<input type="checkbox"/> No
4	Side ropes are clean and in serviceable condition. No knots splices or joints (except above the top step if manufactured in that manner.) Refer to the manufacturer’s written instructions. List any visible damage: _____ _____	<input type="checkbox"/> Pass	<input type="checkbox"/> Fail

**Table A.3 (continued)**

5	Steps are not cracked/broken or bent/warped or worn. Steps are clean and free of paint, protective coatings or dirt that will inhibit the non-slip capability of the steps.	<input type="checkbox"/> Yes <input type="checkbox"/> No
6	Number of replacement steps (maximum of 2): _____	<input type="checkbox"/> Pass <input type="checkbox"/> Fail
7	Step fixtures are secure and tight.	<input type="checkbox"/> Yes <input type="checkbox"/> No
8	Seizings/step securing are in good condition	<input type="checkbox"/> Yes <input type="checkbox"/> No
9	Storage: is the pilot ladder stored in accordance with the manufacturer's instructions?	<input type="checkbox"/> Yes <input type="checkbox"/> No
10	The result of this inspection recorded in the following location: _____ _____	<input type="checkbox"/> Yes
<p>This ladder is fit for ongoing use.</p> <p>Name and rank of senior officer performing inspection: _____</p> <p>Signed by master: _____</p>		

There shall be an annual inspection by the flag State or Classification Society surveyor. See Table A.4 for an example checklist. The flag State or Classification Society can use its own checklist. Results shall be recorded as required by [Clause 7](#).

**Table A.4 — Annual inspection**

Date:		Pilot ladder identification number:
Pilot ladder annual inspection carried out by flag State or Classification Society surveyor.		
1	Review inspection records of pilot ladders. Date of entry into service: _____ If the service life is greater than 30 months, review test records in accordance with <a href="#">6.6</a> .	<input type="checkbox"/> Pass <input type="checkbox"/> Fail
2	Are the manufacturer's instructions for maintenance and use available onboard?	<input type="checkbox"/> Yes <input type="checkbox"/> No
3	Is the ladder stored in accordance with the manufacturer's care and maintenance instructions? Notes: _____ _____	<input type="checkbox"/> Yes <input type="checkbox"/> No
4	Are steps horizontal and evenly spaced (330 mm +/- 20 mm between steps)?	<input type="checkbox"/> Yes/Pass <input type="checkbox"/> No/Fail
5	Steps are not cracked/broken or bent/warped or worn. Steps are clean and free of paint, protective coatings or dirt that will inhibit the non-slip capability of the steps. Timber steps are free of knots.	<input type="checkbox"/> Pass <input type="checkbox"/> Fail
6	Number of replacement steps (maximum of 2): _____ Have the replacement steps been fitted as per manufacturer's instructions?	<input type="checkbox"/> Pass <input type="checkbox"/> Fail
7	Step fixtures are secure and tight.	<input type="checkbox"/> Pass <input type="checkbox"/> Fail
8	Side ropes are in good condition, refer to the manufacturer's instructions for the inspection of the side ropes.	<input type="checkbox"/> Pass <input type="checkbox"/> Fail

**Table A.4** (continued)

9	Seizings/step securing are in good condition, pay particular attention to the termination below the bottom step. Is the side rope tightly wound around a step fixture or fitted with a double seizing and suitably whipped to prevent fraying?	<input type="checkbox"/> Pass <input type="checkbox"/> Fail
10	The ladder is fitted with a legible identification plate below the top step and lowest spreader.	<input type="checkbox"/> Pass <input type="checkbox"/> Fail
11	The result of this inspection recorded in the following location: _____	<input type="checkbox"/> Yes
I hereby certify the above pilot ladder is fit for ongoing use: Name: _____ Classification Society or Inspector's employer: _____ Signed by master: _____		

For use by authorized users of Pilot and Embarkation ladders only

## Annex B (informative)

### Rope ladders — Care and maintenance<sup>1)</sup>

#### B.1 Introduction

Due to its strength, superior grip, good abrasion resistance and low stretch qualities, manila is usually the rope of choice when constructing lifeboat and life-raft embarkation ladders, pilot ladders and Jacob's ladders. In some cases, ropes made from other natural fibres or synthetic materials can be used. Following a recent incident involving the failure of a pilot ladder as shown in [Figure B.1](#), this annex has been written to provide guidance on the care and maintenance of rope ladders.

#### B.2 Properties, stowage and care

A rope made of natural fibre and synthetic materials are susceptible to damage and loss of strength due to a number of factors, if it is not stowed and handled correctly

Abrasion or cuts can occur during routine handling. Bulwarks, fish plates, deck edges, decks and any other surfaces which can come into contact with the ladder should therefore be smooth and free from obstructions or defects that can chafe or cut the rope.

Natural fibres are susceptible to dry rot and mildew; therefore, the rope is normally treated with chemical preservatives in the factory to provide resistance to such problems. However, rope ladders should not be stowed when wet as the preservatives can become less effective over time.

Although a natural fibre rope is resistant to alkalis and to some chemicals, rope ladders should not be stored together with acids, detergents or paint as these products and their fumes can cause the fibres to deteriorate quickly. [Figure B.2](#) provides an embarkation ladder resting on deck exposed to attack by water and cleaning chemicals.

Rope ladders should not be dragged over decks that need cleaning. Abrasive material such as cargo particles or blasting grit can penetrate the strands, and contact with hydraulic oil or fuel residues can cause damage.

If a rope ladder is dirty, it should be washed with fresh water. Soap or detergent should not be used as these products can affect the natural oils and chemical preservatives in the rope. High-pressure water guns should also be avoided as these can force dirt or grit into the fibres. The ladder should be allowed to dry naturally prior to storage, avoiding the use of hot air blowers or heated compartments. Once dry, the ladder should be shaken to remove any particles that can remain.

Ideally, rope ladders should be stored in a cool, dry, well-ventilated compartment and stowed or hung in a manner that allows maximum exposure to the air. If kinks are present, these should be removed beforehand. However, embarkation ladders for lifeboats and life rafts are required, by their very nature, to be stowed on deck, as are pilot ladders on some vessels.

Consequently, rope ladders stored outside should be inspected more frequently to ensure that they are still in good condition. In sub-zero temperatures, they should be thawed thoroughly before use, as frozen rope fibres are more susceptible to breakage.

---

1) SOURCE: see Reference [4].



SOURCE TCI Dakar.

**Figure B.1 — Pilot ladder side rope that failed as a pilot climbed the ladder**



**Figure B.2 — Embarkation ladder resting on deck, exposed to attack by water and cleaning chemicals**

In order to protect rope ladders stored outside from the effects of rot, mildew, chemicals, acids and detergents, they should be stowed on a suitable grating. Wooden pallets, cut down to size, are ideal for this purpose. The height of the grating should be such that the ladder does not come into contact with free water on deck that can contain potentially harmful products.

Rope materials are also susceptible to actinic degradation due to ultraviolet radiation, particularly in tropical areas. Rope ladders stored outside should therefore be covered when not in use to protect them from the effects of sunlight. Coverings also protect ladders from precipitation and frost. An embarkation ladder stowed clear of the deck and suitably covered is shown in [Figure B.3](#).

The shipboard ends of rope ladders stored outside on gratings are often shackled to padeyes, and it is not uncommon to find the rope between the grating and the padeyes uncovered and in contact with the deck. This can result in accelerated deterioration in the vicinity of the eye thimbles due to prolonged exposure to sunlight and water that can contain chemicals. Protecting the rope between the grating and the padeyes should not be over-looked when stowing and covering a rope ladder.

### B.3 Inspection and maintenance

The inspection and maintenance of rope ladders should be included in the vessel's planned maintenance system (PMS). A thorough inspection at least monthly is recommended together with a visual check prior to each use. The entire length of the ladder should be examined, including all fixtures and fittings. Ladders in frequent operation, such as pilot ladders, should be thoroughly inspected more often.

The following points should be borne in mind.

- a) Although the surface of the rope can appear to be in satisfactory condition, natural fibre rope can self-abrade from the inside. Therefore, the lay should be opened at regular intervals along the ladder to check for signs of wear.
- b) The presence of dark mould spots or a grey powdery substance within the lay of the rope can be an indication of rot or mildew, particularly if accompanied by a musty odour. Once mildew has taken hold, it is very difficult to eradicate.
- c) A rope that is stained or has surface fibres, which can be rubbed off easily, can have been attacked by chemicals. Dark brown spots on the outside can indicate that the rope has been in contact with acid or acid fumes.
- d) If the fibres on the surface appear to be weak or frayed and can be picked away with a fingernail, the rope can be suffering from actinic degradation due to exposure to sunlight.

The inspection should also cover the fixtures and fittings:

- spliced tail strands and rope ends should be either whipped or to prevent them from unravelling;
  - any splices with loose tucks should be tightened or renewed.
- e) Steps and chocks should be inspected for damage including cracks, wear, splits, sharp edges and splinters. Checks should be made to ensure that any slip resistant material applied to the steps is still effective. All steps should be horizontal, and none should be painted, either partially or completely, as this may mask the presence of flaws.
  - f) Rot, mildew, chemicals, acids, detergents, paint and sunlight can affect natural fibre seizings in the same way as the rope itself. Their condition should be checked to confirm they have not degraded, even when tarred marlin has been used. Seizings should be intact and tight, holding the wooden chocks or rungs securely in place.
  - g) Shackles securing ladders to padeyes on deck should be inspected to ensure that they are not corroded beyond acceptable limits. Ideally, stainless steel shackles should be used. Shackle pins should be screwed firmly into the shackle body and moused. Shackle bolt nuts should be tight and secured with a stainless-steel split pin.
  - h) Padeyes should be inspected for damage and corrosion, and welds checked for excessive wear down and cracks. It is also important to remember that new requirements regarding the construction, identification, inspection and repair of pilot ladders entered into force on 1 July 2012. See Reference [2].



**Figure B.3 — Embarkation ladder stowed clear of the deck and suitably covered**

#### **B.4 Replacement criteria**

Any damage to, or degradation of, a rope ladder should be evaluated by an appropriately experienced crewmember. If deemed necessary, or if any doubt exists, the ladder should be removed from service and repaired or replaced. Factors that can result in such action include:

- a) fraying, abrasion, cuts or signs of excessive wear;
- b) deterioration (particularly if long fibres pulled from the rope lack strength and break easily);
- c) being splashed/soaked by chemicals, detergent or paint;
- d) powdering between strands;
- e) discolouration (other than benign stains);
- f) rot or mildew;
- g) variations in diameter size;
- h) exposure to overloading or shock loads;
- i) kinks difficult to remove.

If small sections of rope are found to be damaged or weakened, the entire length should be replaced completely. It is not acceptable to crop out the affected areas and reconnect the rope regardless of the method used (e.g. splicing, joining shackles, knots).

Steps, rungs, or chocks that are cracked, worn, split, splintered or painted should be replaced, as should any worn or missing anti-slip material. New chocks should always be secured with fresh seizings. Any seizings found to be in poor condition should be changed.

If it is necessary to replace a rope ladder completely, the old one should be dismantled or destroyed to prevent the possibility of inadvertent use.

Shackles should be replaced if wear or corrosion has reduced the diameter of the crown or pin by more than 10 %.

Padeyes found to be worn beyond Classification Society limits should be renewed. Any cracked welds should be ground out, repaired by a suitably qualified welder, and subjected to non-destructive testing (NDT) thereafter.

For use by authorized users of Pilot and Embarkation ladders only

## Bibliography

- [1] ISO 1181:2004, *Fibre ropes — Manila and sisal — 3-, 4- and 8-strand ropes*
- [2] IMO, *Pilot Transfer Arrangements*, SOLAS, Chapter V, Safety of Navigation, Regulation 23, 2.3 and 2.4
- [3] IMPA, *Required Boarding Arrangements for Pilot<sup>2)</sup>*, available at <https://www.impahq.org/admin/resources/finalimpapladderposter.pdf>
- [4] West of England, Loss Prevention Bulletin, *Natural Fibre Ropes - Care and Maintenance*, available at: <https://www.westpandi.com/getattachment/17804fea-144b-4216-8416-aeb595f7f446/loss-prevention-bulletin-natural-fibre-rope-ladders-care-and-maintenance.pdf>

---

2) Versions in French, Spanish and Chinese can be found at <https://www.impahq.org/downloads.php>.



For use by authorized users of Pilot and Embarkation ladders only

---

---

**ICS 47.020.50**

Price based on 14 pages

# REPLACEMENT STEP

## USER MANUAL FOR SEIZING PART 1

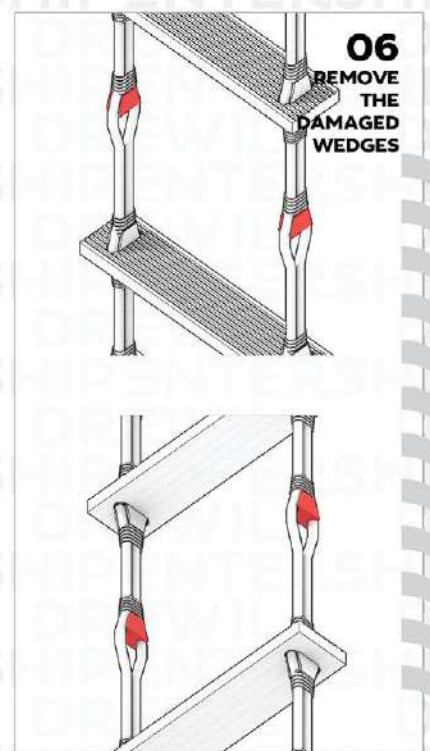
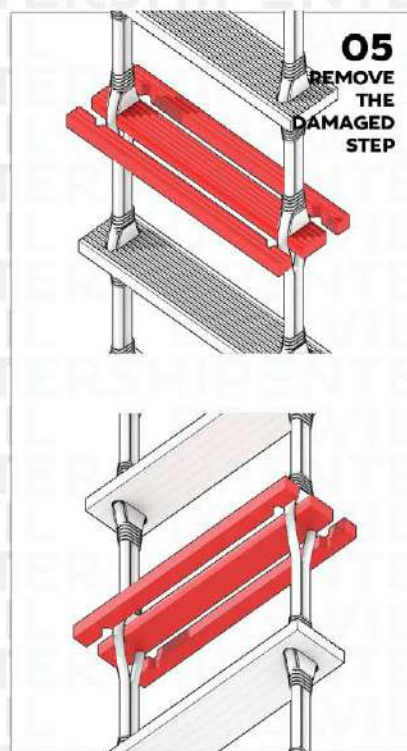
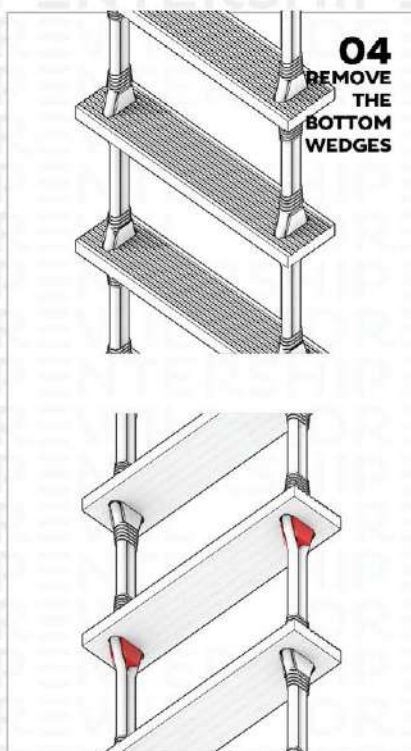
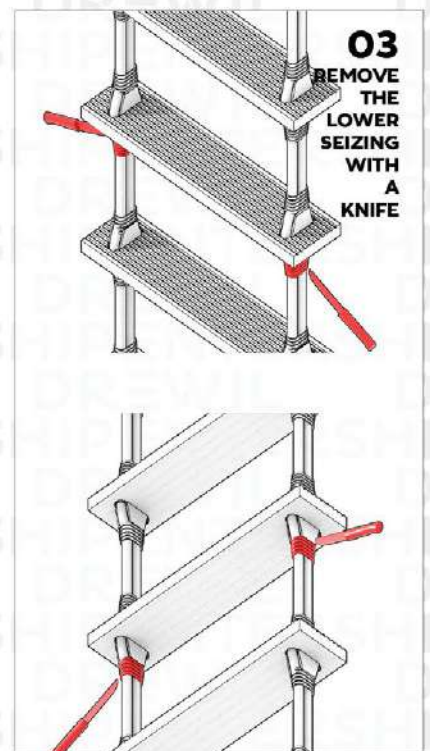
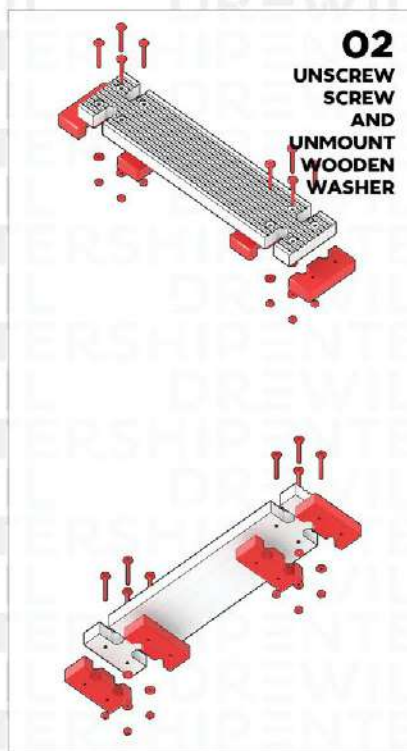
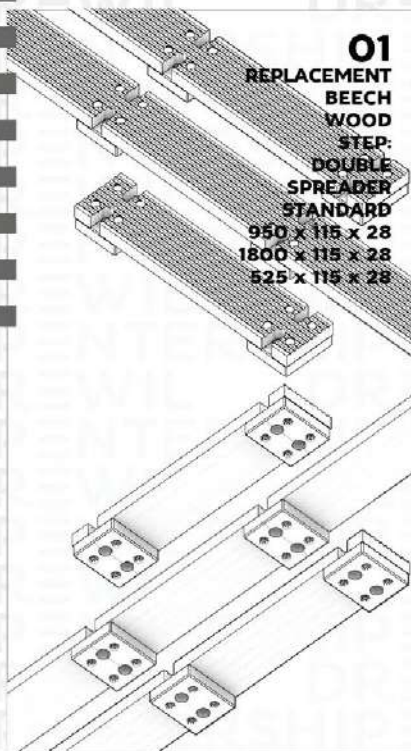

The replacement beech wood step: double, spreader, standard set contains:

- removable wooden /spreader/double/ beech wood step
- M8x60 zinc-plated round head square neck - 8 pcs /12 pcs/
- 8 mm galvanized hexagonal nut - 8 pcs /12 pcs/
- 8 mm galvanized round washer - 8 pcs /12 pcs/
- two-piece wooden washer - 2 pcs /3 pcs/
- wooden wedge - 4 pcs /3 pcs/
- string for seizing fi 4 mm ppv with core l. 165 cm - 4 pcs /6 pcs/
- all dimensions are in mm

# REPLACEMENT STEP

## USER MANUAL FOR SEIZING PART 2

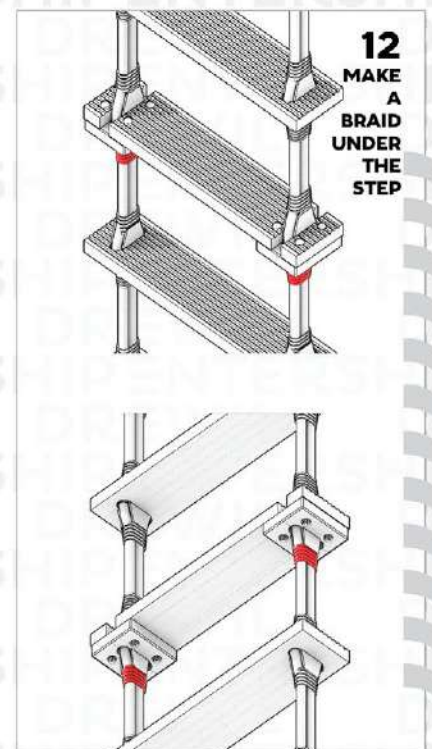
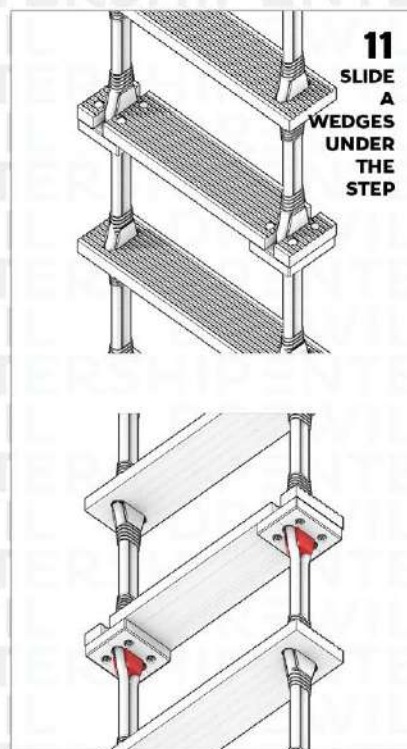
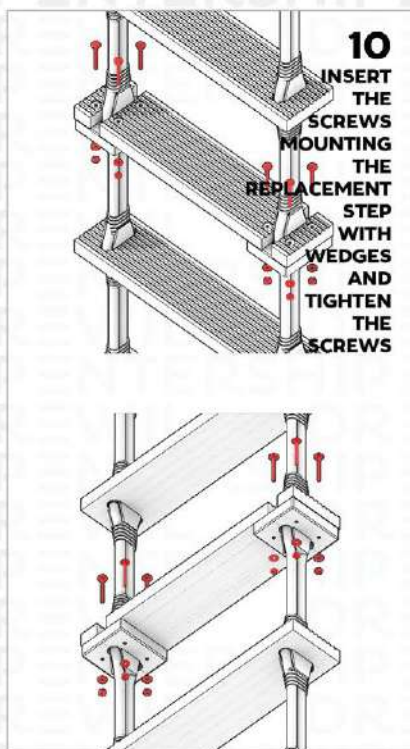
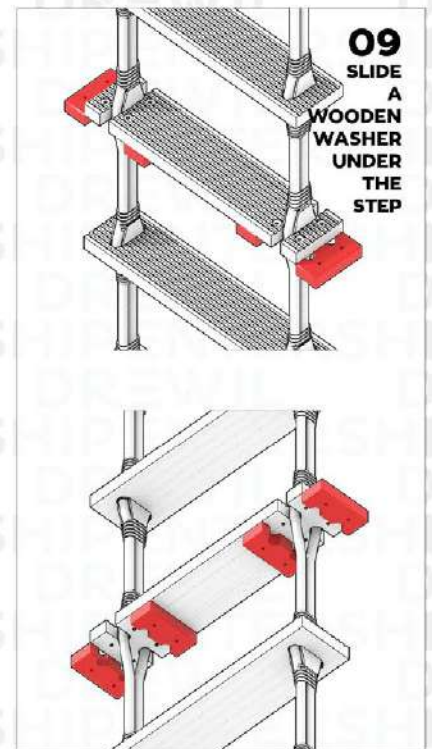
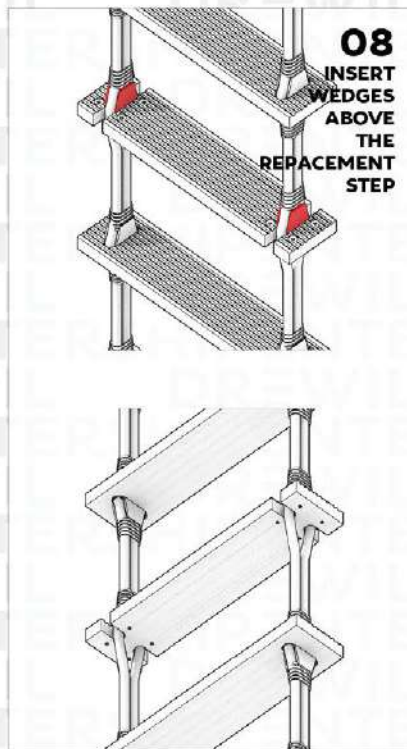
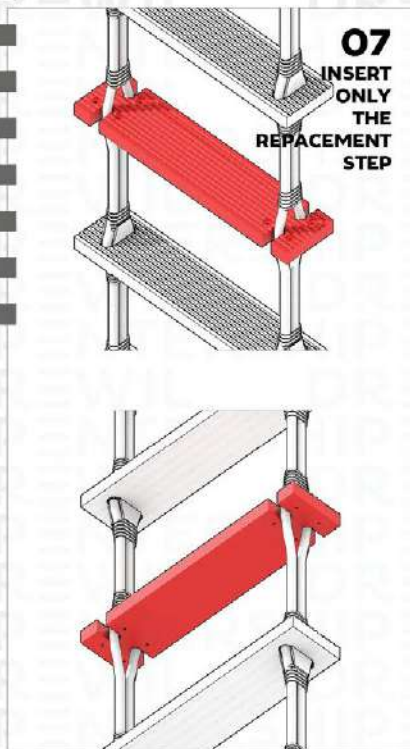

The replacement beech wood step: double, spreader, standard set contains:

- removable wooden /spreader/double/ beech wood step
- M8x60 zinc-plated round head square neck - 8 pcs /12 pcs/
- 8 mm galvanized hexagonal nut - 8 pcs /12 pcs/
- 8 mm galvanized round washer - 8 pcs /12 pcs/

- two-piece wooden washer - 2 pcs /3 pcs/
- wooden wedge - 4 pcs /3 pcs/
- string for seizing fi 4 mm ppv with core l. 165 cm - 4 pcs /6 pcs/
- all dimensions are in mm

File **REPLACEMENT STEP S P2** Draw. date 14/05/2020

MED, DNV-GL, RMRS Approval

Compliant with ISO 799-1:2019 (E), ISO 5489:2008(E)

**DREWIL**  
**ENTERSHIP**

**DREWIL ENTERSHIP**  
3 Szkolna Street  
83-305 Pomieczyño, POLAND  
+48 58 681 50 21  
info@drewilentership.com  
drewilentership.com

