

1 For your safety

These instructions are intended for trained and competent users of respiratory protection equipment and breathing air supply systems. The document provides instructions for the safe use, handling and maintenance of steel, aluminium and carbon-composite compressed air cylinders supplied by Dräger.

1.1 General safety statements

- Before using this product, carefully read the Instructions for Use.
- Strictly follow the Instructions for Use. The user must fully understand and strictly observe the instructions.
- Use the product only for the purposes specified in the Intended Use section of this document.
- Do not dispose of the Instructions for Use. Ensure that they are retained and appropriately used by the product user.
- Only fully trained and competent users are permitted to use this product.
- Comply with all local and national rules and regulations associated with this product.
- Only trained and competent personnel are permitted to inspect, repair and service the product.
- Dräger recommend a Dräger service contract for all maintenance activities and that all repairs are carried out by Dräger.
- Properly trained service personnel must inspect and service this product as detailed in the Maintenance section of this document.
- Use only genuine Dräger spare parts and accessories, or the proper functioning of the product may be impaired.
- Do not use a faulty or incomplete product, and do not modify the product.
- Notify Dräger in the event of any component fault or failure.
- The air supply shall meet the requirements for breathing air according to EN 12021.

1.2 Definitions of alert icons

Alert icons are used in this document to provide and highlight text that requires a greater awareness by the user. A definition of the meaning of each icon is as follows:

WARNING
 Indicates a potentially hazardous situation which, if not avoided, could result in death or serious injury.

CAUTION
 Indicates a potentially hazardous situation which, if not avoided, could result in physical injury or damage to the product or environment. It may also be used to alert against unsafe practices.

NOTICE
 Indicates additional information on how to use the product.

2 Description

2.1 Product overview

Dräger compressed air cylinders are designed and manufactured according to the requirements of the Pressure Equipment Directive (PED). The cylinders have the CE conformity marking to indicate that they have undergone an approval assessment by a relevant notified body. The cylinder is rated at a working pressure of 200 bar or 300 bar, and the cylinder body and cylinder valve are labelled with the pressure rating (see Section 2.5).

Cylinders supplied by Dräger are normally supplied fully charged unless shipping/transportation regulations prevent this. Fully charged cylinders are filled with breathing air (according to EN 12021) to the working pressure at 15 °C.

2.1.1 Cylinder valve

The cylinder is fitted with one of the cylinder valve types available, including straight, right-angled or cross-flow valves (Fig A). The cylinder valve is rated at the same working pressure as the cylinder. The cylinder valve outlet is normally a G5/8" connector as per EN144-2, although other connector types are available.

Options available for the cylinder valve include a standard (non-ratchet) or ratchet type hand wheel, an excess flow valve (EFV), and an integral pressure gauge, all of which are described later.

The hand wheel is black unless the valve contains an excess flow valve in which case it is grey or blue (see Section 2.1.3).

2.1.2 Non-ratchet and ratchet type hand wheels

The cylinder valve has a non-ratchet or ratchet type hand wheel (Fig B).

- For a non-ratchet type, the hand wheel turns freely in each direction.
- For a ratchet type hand wheel, the ratchet mechanism is intended to prevent inadvertent closing of the valve. The hand wheel turns freely when opening the valve but is restricted by the ratchet mechanism during cylinder closing. To close the valve it is necessary to lift the hand wheel over the ratchet, against spring force, and simultaneously turn the hand wheel clockwise.

2.1.3 Excess flow valve

An excess flow valve (EFV) is an option available for air cylinders. When fitted, the excess flow valve is a safety device which prevents uncontrolled release of high-pressure air in case of cylinder valve or high-pressure air pipe damage. The excess flow valve also activates if the cylinder valve is opened when the cylinder valve outlet is open to atmosphere.

The excess flow valve activates to reduce the rate of escaping air when required, but does not affect performance during normal use.

Cylinder valves containing an excess flow valve have a grey hand wheel in most countries, but have a blue hand wheel in some countries (e.g. Switzerland) to comply with national regulations.

2.1.4 Integral pressure gauge

An integral pressure gauge is fitted on some cylinders valves to indicate the air pressure remaining in the cylinder. The pressure gauge connects to the cylinder side of the cylinder valve to provide a constant pressure reading, including when the cylinder valve is closed.

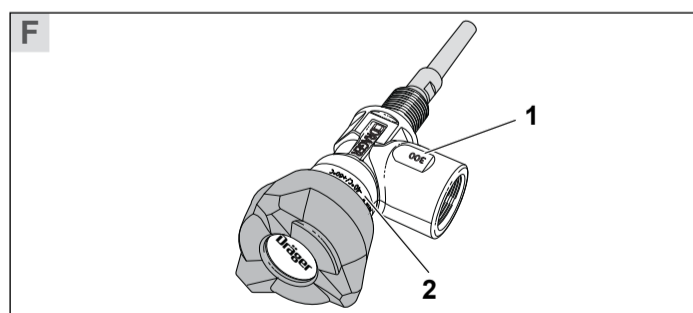
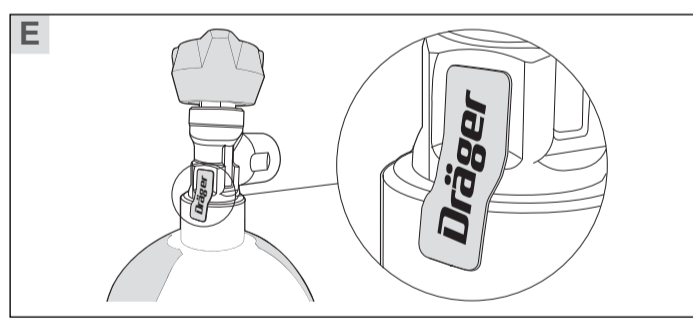
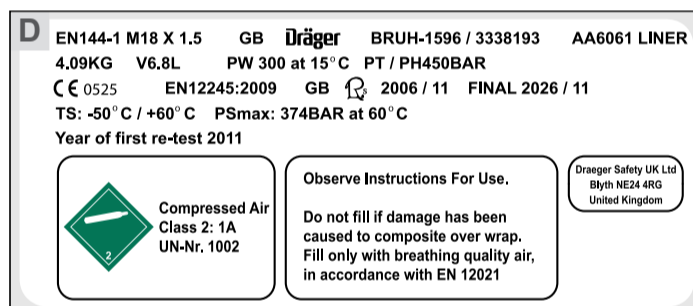
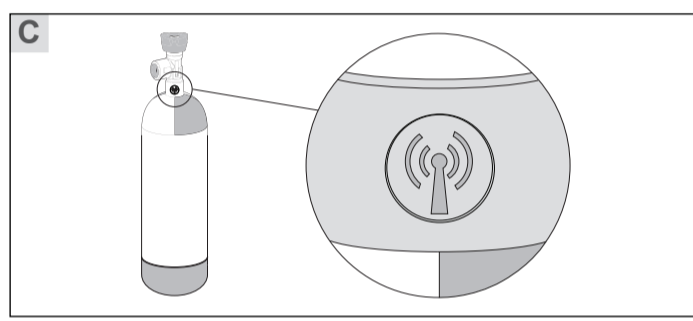
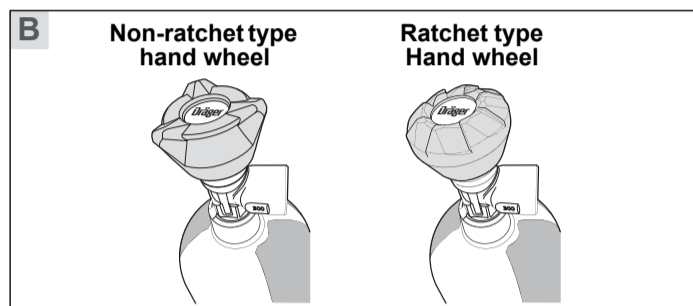
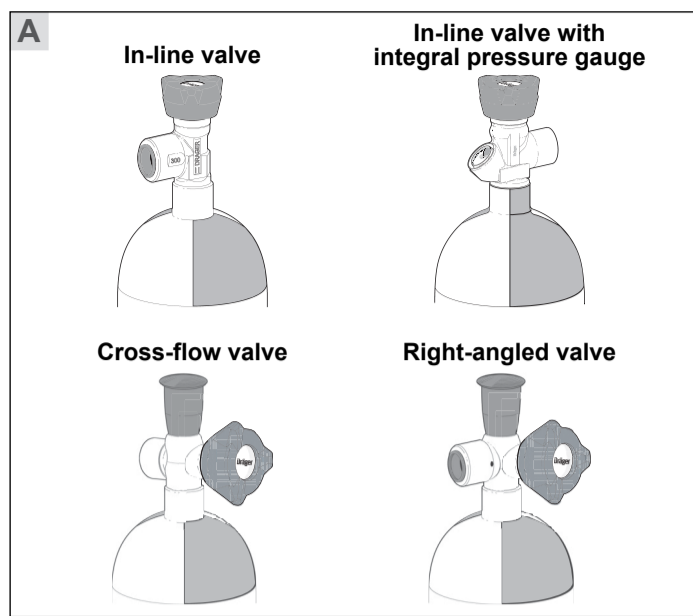

2.1.5 RFID

RFID (radio-frequency identification) is an option available for air cylinders to allow electronic asset management and tracking using a radio-frequency reader. When fitted, the RFID tag is positioned in a rubber collar on the neck of the cylinder (Fig C).

2.2 Intended use

Dräger compressed air cylinders are intended to supply breathing air to compatible Dräger respiratory protection equipment and breathing air supply systems which are approved to one of the following technical standards: EN137, EN402 or EN1146. When fitted to an approved Dräger respiratory protection device, the cylinder provides the wearer with respiratory protection for working in contaminated or oxygen-deficient conditions.

For the cylinder operating temperature range see the associated breathing apparatus instructions for use. The cylinder, liner, and cylinder valve temperature ranges on product labels and in this document are information for manufacturers only.

2.3 Limitations on use

Dräger compressed air cylinders are not approved for scuba diving and should not be immersed in fresh or salt water.

2.4 Approvals

The European standards, guidelines, and directives according to which this product is approved are specified in the declaration of conformity (see declaration of conformity or www.draeger.com/product-certificates).

Users must ensure that the cylinders comply with any relevant national regulations in the country of use. Contact Dräger, a national approval agency or an accredited test station for advice if necessary.

2.5 Explanation of marking and symbols

2.5.1 Cylinder marking

The cylinders are intended for breathing air only and are labelled and colour coded according European standards. The cylinder colour coding is painted on the shoulder of the cylinder.

An example of the information shown on a Dräger carbon-composite cylinder label is shown in Fig D and explained in the table below.

Marking	Explanation
EN144-1 M18 X 1.5	Thread standard and size
GB	Country of manufacture
Dräger	Name of manufacturer
BRUH-1596 / 3338193	Unique serial number / Drawing number of approved design
AA6061 LINER	Cylinder liner alloy specification
4.09KG	Nominal unpressurized weight in kilograms, without valve
V6.8L	Minimum water capacity in litres
PW 300 at 15 °C	Maximum working pressure in bar, at a reference temperature of 15 °C
PT / PH450BAR	Test pressure
CE 0525	CE marking and identification number of notified body
EN12245:2009	Standard which specifies the design, testing and production of the cylinder
GB	Country of approval and mark of the notified body
2006/11	Date of first hydrostatic pressure test. Alternatively shown in month/year format (03/2014 or 03/14)
FINAL 2026/11	End of design life, after which the cylinder should not be used. Alternatively shown as FIN 2026/11
TS: -50 °C / +60 °C	Operating temperature range
PSmax: 374BAR at 60 °C	Maximum developed cylinder pressure at 60 °C
Year of first re-test 2011	This date reflects the relevant national regulations for cylinder periodic inspection in the country of use. The cylinder should be recertified before the end of the month of the first hydrostatic pressure test (November in this case)
	Indicates a non-oxidising compressed gas

An adhesive label (Fig E) is placed across the joint between the cylinder neck and the cylinder valve when the valve is fitted during manufacture. The label indicates that the joint is subject to approval in accordance with the Pressure Equipment Directive (PED), and identifies the cylinder as an authentic Dräger product.

The label should be present and intact on initial receipt of the cylinder – if not, please contact Dräger or your supplier. The label can become broken or detached during the life of the cylinder, and this does not have any detrimental effect on the cylinder.

2.5.2 Cylinder valve marking

The cylinder valve marking (Fig F, Item 2) is engraved around the valve body and the working pressure (Fig F, Item 1) is marked on the valve body or the outlet port. An example of the valve marking and the explanation is:

K800-502.0-S8 EN144 TT-0589 XX/XX M18 F -40°C/+60°C

Marking	Explanation
K800-502.0-S8	Valve type
EN144	Applied standard
π	Indicates that the valve meets the Transportable Pressure Equipment Directive (TPED) requirements
0589	Identification number of the notified body
XX/XX	Year and month of manufacture
M18	Cylinder thread
F	In accordance with EN137
-40 °C/+60 °C	Temperature range

3 Use

3.1 Cylinder handling

- Compressed air cylinders are heavy and can be difficult and awkward to move. Improper handling could result in injuries or death. When handling cylinders take all necessary precautions to prevent accidents.
- Only trained and competent personnel, familiar with the correct handling techniques and the hazards associated with compressed air cylinders, should handle cylinders.
- Advise untrained personnel about the hazards associated with handling, transportation and storage, and do not allow them to handle compressed air cylinders.
- Hold the valve body or the cylinder body to carry the cylinder. Do not carry the cylinder by holding the valve hand wheel.

3.2 Preparing and using the cylinder

3.2.1 General statements

- Carry out a visual inspection of the cylinder (see Section 4.4).
- Ensure that the cylinder is within the design life and the periodic inspection indicated by the test date on the cylinder.
- Before fitting the cylinder to the respiratory protection equipment, remove the protective cap from the cylinder valve outlet. Retain the cap for refitting.
- Fit the cylinder and carry out leak and functional tests as described in the Instructions for Use provided with the respiratory protection equipment.
- Do not commence any operation using a cylinder that is less than 90 per cent full (or greater when required by national regulations). If the cylinder is less than 90 per cent full, charge the cylinder to the full rated working pressure (see Section 4.3).
- The duration of protection is dependent on amount of air available from the cylinder and the breathing rate of the wearer.

3.2.2 Operating the cylinder valve

WARNING
Do not open the cylinder valve unless the cylinder is connected to breathing equipment or a test gauge.

CAUTION
Do not apply excessive force or use tools to open or close a cylinder valve.

- To open the valve, turn the hand wheel fully anticlockwise (looking at the top of the hand wheel).
 - A ratchet-type hand wheel will lift over the ratchet lugs during opening.
 - Once a ratchet-type hand wheel is fully open, turn the hand wheel clockwise less than 60° to engage the first ratchet in order to prevent inadvertent closing of the valve.
- To close the valve, turn the hand wheel fully clockwise.
 - For a ratchet-type hand wheel, simultaneously lift the hand wheel over the ratchet lugs and turn clockwise.
- To fully open or fully close the valve, turn until a resistance is felt and no further rotation is possible. This ensures:
 - There is no restriction to the air when the valve is open.
 - Air release is prevented when the valve is closed.
- From the fully closed to the fully open position requires more than two full revolutions of the hand wheel.

3.3 After use

- Immediately after use close the cylinder valve to prevent moisture from entering the cylinder.
- If required, remove the cylinder from the respiratory protection equipment as described in the Instructions for Use provided with the equipment. If the cylinder is removed, immediately refit the protective cap to the cylinder valve outlet.

4 Maintenance

4.1 Maintenance table

Maintain and test the cylinder, including out-of-use cylinders, in accordance with the maintenance table. Record all maintenance details and testing. Additional inspection and testing may be required in the country of use to ensure compliance with national regulations.

Component/System	Task	Before use	After use	Every month
Cylinder	Inspect, and clean if necessary	○	○	○
	Check test date of cylinder	○		○
	Check charged pressure	○		○
	Charge to the working pressure (see Section 4.3)	○		
	Periodic inspection (see Note 1 below)		According to national regulations in the country of use	
Cylinder valve	Overhaul (see Note 1 below)	At the time of cylinder periodic inspection		

Notes

○ Dräger recommendations

1 These maintenance tasks may only be carried out by a competent cylinder technician. Cylinder owners/users should contact Dräger or an accredited test/repair station when the tasks are required.

4.2 Cleaning

CAUTION
Cleaning using grit or shot blasting, chemical cleaning agents, paint strippers and solvents could damage the cylinder or cylinder valve. Do not use cleaning methods or materials that could cause damage.

When required, clean the cylinder using a mild soap based detergent. Contact Dräger or other competent service personnel if further cleaning is required.

4.3 Recharging air cylinders

WARNING
Air quality for compressed air cylinders must conform to requirements of EN 12021.

- Dräger cylinders are intended only for use with compressed air breathing equipment. Only charge cylinders with breathing quality air – no other mixtures or single gases are allowed.
- Refer also to the instructions supplied with the charging unit for recharging the cylinder.

- Carry out a visual inspection of the cylinder (see Section 4.4).
- Only charge compressed-air cylinders which:
 - Conform to national standards.
 - Are marked with the date of the last periodic inspection and the identification symbol or name of the accredited test station.
 - Are within the design life and are not overdue the next periodic inspection.
 - Are not damaged or corroded.
- To prevent ingress of moisture into the cylinder, ensure that the cylinder valve remains closed until connected to the charging unit.
- To prevent overcharging of the cylinder, Dräger recommend using a pressure-limiting device on the charging compressor.
- Dräger recommend a maximum charge rate of 27 bar/minute (rapid charging will increase the temperature resulting in an incomplete charge).
- Recharge to the rated working pressure (PW on the cylinder label):
 - Cylinder temperature increase during charging will cause the cylinder pressure to increase. If the cylinder is filled at the maximum charge rate, the pressure increase above the working pressure may be significant. The maximum permissible pressure increase is 10 % of the working pressure. For example, a 300 bar cylinder can rise to a maximum of 330 bar.
 - After charging, allow the cylinder to cool and then recheck the pressure. The cylinder pressure at 15 °C must not exceed the maximum rated working pressure that is marked or stamped on the cylinder – top up or release pressure if necessary.

4.4 Inspecting cylinders

4.4.1 Visual Inspection

If the cylinder is fitted with a protective cover, remove the cover before inspecting the cylinder.

Thoroughly inspect the cylinder and valve, ensuring that they are clean undamaged. Typical signs of damage that may affect the cylinder include impact, abrasion, cutting, corrosion and discolouration. Report damage to service personnel or Dräger, and do not use the cylinder unless it is safe to do so.

4.4.2 Dräger carbon-composite cylinders

All damage to Dräger carbon-composite cylinders requires expert inspection to ensure that the cylinder is safe for continued use. Contact service personnel or Dräger if damage occurs.

An inspection manual and a poster provide inspection advice about damage from: cuts, abrasion, impact, heat/fire and chemicals. The manual and poster are intended for trained service personnel, and are available from Dräger on request.

Illegible cylinder label

The label on the cylinder must be legible as it contains essential safety information. If the label is illegible, return the cylinder to Dräger for assessment. If Dräger can identify the cylinder, it may be possible to fit a replacement label and return the cylinder to the owner. Otherwise, the cylinder will be removed from use.

Cylinder neck gap

Some carbon-composite cylinders have a small gap between the composite material and the cylinder neck (Fig G). This appears as a gap in the gel coating or a crack in the paint, and can appear larger when the cylinder is fully charged. The gap is not a fault; it occurs on some cylinders due to expansion/contraction as the cylinder is charged and discharged. The neck gap does not reduce the operating safety of the cylinder, and is not a reason to condemn the cylinder or request repair.

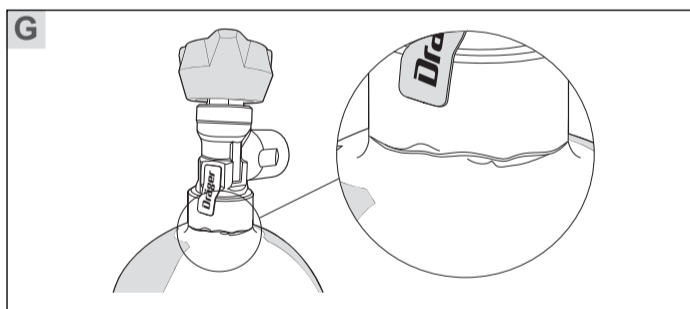

4.5 Cylinder periodic inspection

Periodic inspection is an examination of the cylinder which must be carried out by an accredited test station. The examination includes a visual inspection and a hydrostatic pressure test to ensure that the cylinder is still safe, and to recertify it for continued use.

The dates of the first hydrostatic pressure test (carried out during manufacture) and the first required periodic inspection are marked on the cylinder during manufacture. The date of subsequent periodic inspections is marked on the cylinder by the test station which carries out the inspection.

Dräger cylinders must have a periodic inspection in accordance with the relevant European standards or national regulations in the country of use. The frequency is currently every five years for EU countries. When periodic inspection is due, the cylinder should be recertified before the end of the month shown for the date of the first hydrostatic pressure test.

4.6 End of design life

For cylinders with a limited life, the end of design life is the date after which the cylinder should not be used. It is normally recorded on the cylinder as FINAL or FIN with a date. Composite cylinders with a limited life have a life of 15, 20 or 30 years as indicated by the marking on the cylinder.

Some cylinders have a non-limited life. Composite cylinders with a non-limited life are marked NLL to indicate that the cylinder life is non-limited. All steel and aluminium cylinders have a non-limited life and therefore do not have any marking to indicate the end of life.

The design life of a cylinder is only valid if the necessary periodic inspections are carried out and the cylinder is not damaged.

4.7 Cylinder repair

Do not attempt any repairs to the cylinder or valve, and do not remove the cylinder valve from the cylinder. Contact service personnel or Dräger if repairs are required.

A technical manual is available from Dräger for competent cylinder technicians. The manual provides a description and the maintenance and repair procedures for cylinders and valves. Contact Dräger for further information.

5 Transportation and Storage

Dräger recommend the following measures during transportation and storage to protect cylinders against damage and to reduce the risk of internal contamination.

- Fully close the cylinder valve and fit a protective valve cap.
- Ensure that the cylinder is not completely discharged – Dräger recommend keeping a minimum pressure of 2 bar in the cylinder.
- Inspect stored cylinders for damage and check the cylinder pressure regularly (at least monthly).
- Transport and store cylinders in dedicated facilities, and observe the following recommendations:
 - Do not expose cylinders to flames or potentially damaging temperatures. The storage temperature range for charged cylinders is -30 to +60 °C.
 - Do not expose cylinders to contamination by fine dust or grit.
 - Do not expose cylinders to corrosive substances.
 - Securely fix cylinders during transportation to prevent impact damage, and ensure that cylinders do not project beyond the sides or ends of any transportation vehicle.
 - Transport and store cylinders in their original packaging if possible.
 - Separate full cylinders from empty cylinders and clearly identify the storage areas.

6 Disposal

NOTICE
Do not dispose of the cylinder in accordance with normal regulations for waste disposal.

A cylinder which is beyond the end of its design life or is found on inspection to be damaged beyond repair must be destroyed. Cylinder destruction can only be carried out by Dräger or an accredited test/repair station, and involves damaging the cylinder sufficiently to prevent it from holding gas under pressure. Contact service personnel or Dräger if cylinder destruction is required.