

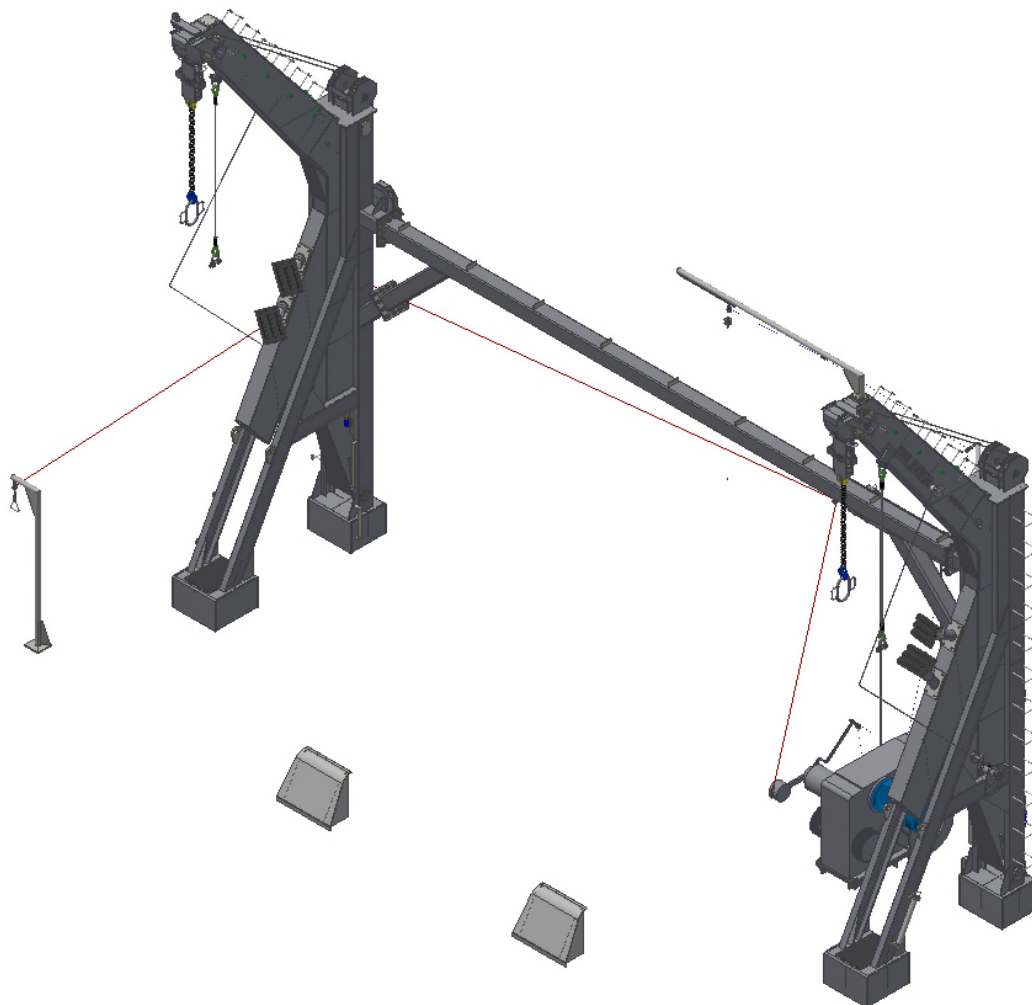

**VIKING
NORSAFE**
Boats and davits

Enterprise No.: NO940411696
www.VIKING-life.com

E-150 – Single Pivot Gravity Davit



TECHNICAL SPECIFICATION

VIKING Norsafe Life-Saving Equipment Norway AS
Tybakken 90, N-4818 Faervik
P.O. Box 115, N-4852 Faervik
Arendal, Norway

VIKING Project No.: TBA

VIKING Doc. No.: TSD-0054

Rev. Date: 15.04.2020

Rev. No: 6

Tel: +47 37 05 85 00

Fax: +47 37 05 85 01

E-mail: VIKING-Norsafe@VIKING-life.com

1. REGULATION AND CERTIFICATION

Applicable rules and regulations	In accordance with IMO/ SOLAS requirements, LSA Code and European Council Directive 2014/90/EU on Marine Equipment (MED)
Certificate	MED
Other certificate	Class certificate or flag acceptance on request

2. DAVIT SPECIFICATION

2.1. GENERAL DAVIT

Type	Single Pivot Gravity Davit
Model	E-150
Application	Conventional Lifeboat handling
Drawing reference	G-500360
Execution	Gravity lowering davit
Boarding position	Inboard / Outboard on deck level
Operating position	From deck side and from inside the boat (Gravity lowering)
Davit system weight (Approx.)	10400 kg, davit incl. winch (dry weight)
Safe Working Load (SWL)	15290 kg
Trim / list conditions	10° / 20°
Max. lowering height	44 m (including 10°/20° trim/list condition)
Operation temperature	-20°C till +45°C (other range on request)
Hoisting speed	0~5 m/min
Min. lowering speed	According to SOLAS regulation ($S = 0.4 + 0.02H$)
Manual hoisting	By manual hand-cranking
Pivot bearing type	Bronze bearings, self-lubricating type
Wire sheaves	Galvanized, equipped with ball bearings
Installation	9 (nine) deck welding points
Deck reinforcement requirements	See general arrangement drawing
Davit system H / W / D	See general arrangement drawing
Deck space required	See general arrangement drawing

The Viking Norsafe Single Pivot Gravity Davit system is especially designed for safe and efficient launching and retrieval of a Viking Norsafe Conventional Lifeboat. The davit system is designed for long time operation in a tough and corrosive marine/offshore environment. The davit system is designed to fulfil all requirements as given in latest SOLAS/IMO requirements.

The system will allow:

- Launch of lifeboat in maximum load condition
- Gravity lowering of the loaded lifeboat independent of external power supply
- Retrieval of lifeboat with a crew of three persons using electric power
- Retrieval of the lifeboat by manual hand-cranking
- Optional approval for rescue function, according to latest SOLAS regulations



VIKING Project No.: TBA

VIKING Doc. No.: TSD-0054

Rev. Date: 15.04.2020

Rev. No: 6

The davit system comprises of two davit arms, a davit structure and an electrically powered winch operating two wire falls. The winch is deck mounted. The davit is intended for lifeboats placed onboard vessels, where swing out davit arms offer the best solution. The lifeboat is normally boarded in the stowed position.

The Single Pivot Gravity (SPG) Davit is based on a well known concept. Swing out and lowering is in one continuous movement and the lifeboat is launched in the minimum time. The winch brake is being released by the operator, on deck or from within the lifeboat. When the brake is released, the davit arms will swing out and the boat will be lowered to the water line in one continuous movement.

The davit is designed to achieve optimum performance in terms of safety and reliability, and minimal maintenance levels. The davit is designed to minimize noise emission and provide straightforward service access.

To activate the davit, push and hold down the appropriate button to activate winch hoisting. When the button is released, hoisting will cease immediately.

A thermal overload relay in the starter cabinet prevents the electrical motor against overheating in case of excessive loads.

The winch is fitted with a one-way clutch. In the event of power loss during hoisting, the brake will automatically activate and davit motion will stop. A centrifugal brake is located on the winch. The brake controls the speed of descent for the lifeboat. The brake is enclosed, and provides reliable operation in all climate conditions.

Electrical limit switches located on the davit arms are used to cut power to the winch when the retrieved boat reaches its stowed height and the davit arms are correctly located. Electrical limit switch on the winch provide failsafe operation of the hand crank.

2.2 WINCH AND WIRE

Type	NW-120 winch
Drawing reference	G-501726
Wire rope type	Galvanized, rotation resistant (certified item)
Wire rope diameter, MBL and spec.	Ø 18 mm, MBL 229 kN, 1960N/mm ²
Inner / outer wire end	Secured to drum / Wedge socket and safety wire clamp
Wedge socket	Included
Master link w/handle	Included (certified item)

2.3. ELECTRICAL

Electric power supply	440V/3ph/60Hz (other on request)
Electrical cabinet	IP56
Remote control	IP56
Limit switch	IP56
Power consumption	32.4 KW
Starting method	DOL - Direct on line
Duty rating	S2-10min



Motor space heating	Included, 40W
Electrical cabinet heating	Heat loss from 42V transformer
Wiring	Included, (only power supply cable required)
Wiring	Included, (only power supply cable required)
Transformer	Included, 440/42VAC (other on request)
Emergency stop	Yes, mushroom type

2.4. PAINTING SYSTEM

Blasting	SA 2.5
Specification	ISO 12944-5
System	Marine paint system (Jotun paint system)
Coating Two (2) layers (other on request)	Layer 1 Penguard universal, Alu - 220 µm Hardtop XP - 80 µm RAL 9016 (Traffic white)
Total dry film thickness	300 µm

2.5. DOCUMENTATION

Technical specification davit	According to contract specification
General arrangement drawing	According to contract specification
Electrical wiring diagram	According to contract specification
Starter cabinet drawing	According to contract specification
Product certificate	According to contract specification
Lubrication oil chart	Viking Norsafe standard
Spareparts list	Viking Norsafe standard
Operation & Maintenance manual	Viking Norsafe standard
Installation manual	Viking Norsafe standard
Preservation & storage procedure	Viking Norsafe standard

3. PACKING

Format **Packed for transport in a 40 ft standard container**

4. OPTIONS

Note: Some options influence davit weight and performance, some option combinations may be incompatible. Maximum SWL must not be exceeded.

marking means to be supplied by maker, marking means not supplied by maker.

GENERAL DAVIT	
Hoisting fully loaded boat	<input type="checkbox"/>
Damping system for main wire fall	<input type="checkbox"/>
Additional lowering height	<input type="checkbox"/>
Additional shock absorber on winch	<input type="checkbox"/>
Additional manual handling crane for electric motor on winch	<input type="checkbox"/>



VIKING Project No.: TBA
Rev. Date: 15.04.2020

VIKING Doc. No.: TSD-0054
Rev. No: 6

Additional supports for lights, lanterns, starter cabinet etc.

Winterization / cold climate heating / canvas solutions

Commissioning performed by Viking Norsafe or Viking Norsafe Service Partners

Other options on request

ELECTRIC SYSTEM

Voltage variation

Protection box for remote control

Ex-proof, Zone II 2 G Ex de IIB T3 (other on request)

Star Δ starting method

Additional electric cabinet heater

Alternative cabinet size / material / surface protection

PAINTING SPECIFICATION

Norsok M-501 system (Viking Norsafe Doc. No. TSS-0030)

Other painting system and final color

SPARE PARTS

Spare parts for Startup / Commissioning

Spare parts for Onboard spare

Spare parts for 1 year

Spare parts for 2 years

DOCUMENTATION

Factory acceptance test procedure

Factory acceptance test report

Inspection and test plan

Shipping, handling and lifting procedure

Packing & unpacking procedure

Commissioning procedure

TAG list

Winch drawing

Noise test report

Weight and COG datasheet

Weighing report/certificate

Other drawings/documentation/procedures

5. POSSIBLE BOAT FITTING THIS DAVIT SYSTEM

The VIKING Norsafe boats fit the E-150 davit types and variants.

JYN-100

Evolution-90



VIKING Project No.: TBA

VIKING Doc. No.: TSD-0054

Rev. Date: 15.04.2020

Rev. No: 6

(Others on request)

6. YARD SUPPLY / RESPONSIBILITY

Transport	Depending on contract
Deck foundations / reinforcement Assembly, erection and welding to deck	
Wire installation on winch, routing on davit and termination All cables to starter cabinet and agreed interface	
Hydraulic oil filling of winch Testing according to regulation after installation onboard	
Preservation and maintenance after davit arrived yard and installed	