

A (1:50)

Magnum-850 Twin Outboard
Technical Data:
 Length overall: 9.5m
 Length on fender: 8.37m
 Breadth overall: 3.27m
 Height: 3.5m
 Capacity: 12 persons
 Weight (Fully equipped): 3350
 Light weight (RCD): 2350kg
 Maximum total weight: 6200kg
 Speed with 3 pers: 30-50 knots

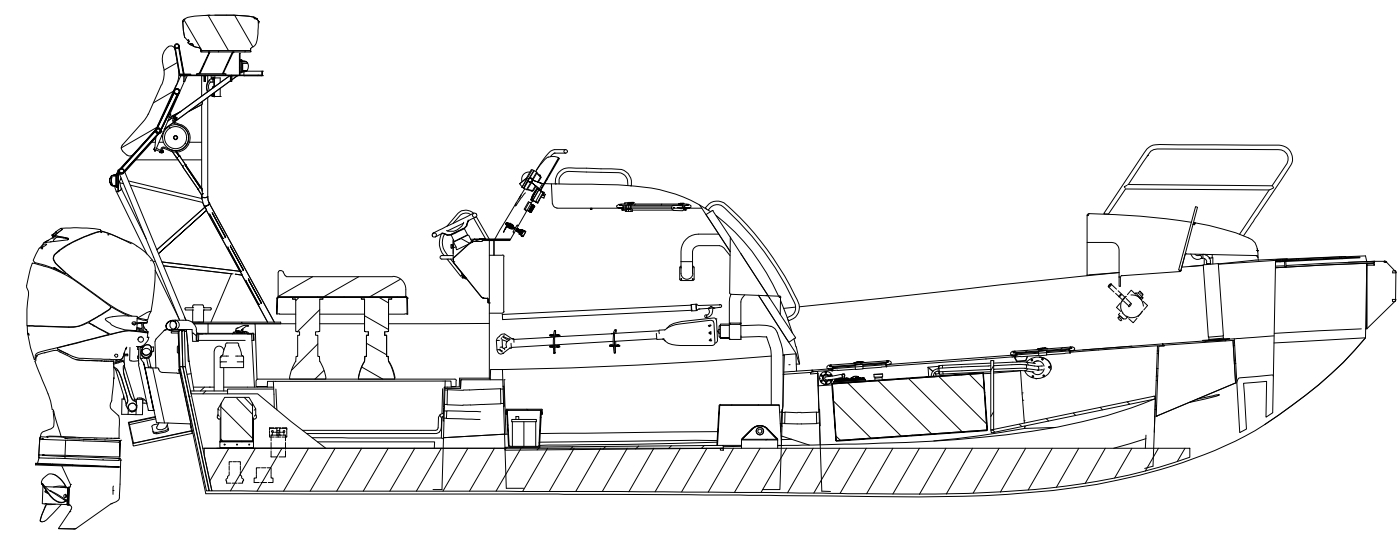

A-A (1:50)

REV	DESCRIPTION	BY	CHECK	APPRO	DATE
2	Updated template	OSK	SAN	ATE	05.08.2019
1	Revised dimension / measurements	JOMY	SAN	SAN	12.03.2018
0	Issued for construction	SAN	KMN	TOH	26.05.2015

		VIKING NORSAFE VIKING Norsafe Life-Saving Equipment Norway AS P.O Box 115 Tel: +47 37 05 85 00 4852 Faervik Fax: +47 37 05 85 01 NORWAY 24/7 Service: +47 37 05 63 33 Email: Viking-Norsafe@viking-life.com	
DWG SIZE: A3 SCALE: COPY OF:		PART NO. WEIGHT. SHEET: 1/1	
CLIENT NO. PROJECTION METHOD:		Magnum-850 Twin Outboard	
TOLERANCES: ISO 2768-mk, ISO 13920-BF		REVISION: 2	
DWG No: G-501443		PROJECT: General Arrangement	